



MACKIE HOOK-UP GUIDE



CFX SERIES



OUR [IN]FAMOUS PRODUCT
HOOKUPS IN BYTE-SIZED MORSELS

Copyright © 2002 Mackie Designs Inc. All Rights Reserved.

TS Plug (mono)

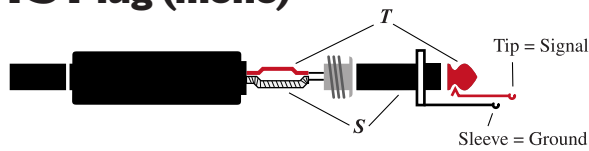

Standard mono/unbalanced phone plug used for most mixer connections.

TRS Plug (stereo)

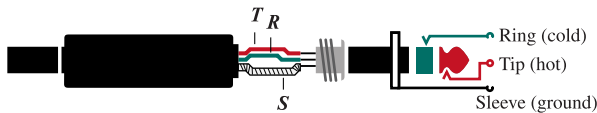

Standard stereo/balanced phone plug used for balanced connections on Mackie mixers.

Balanced XLR

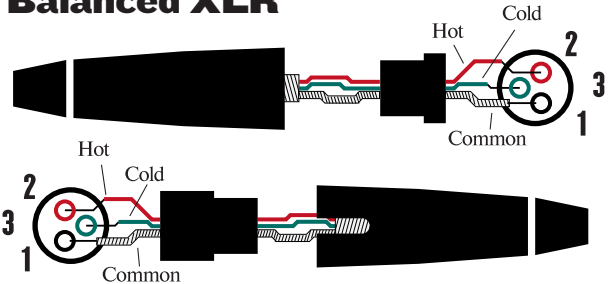

Standard XLR microphone connector to be used with mic-level.

RCA/Phono Plug



Tape deck connections on most Mackie mixers.

Insert "Y" Cable

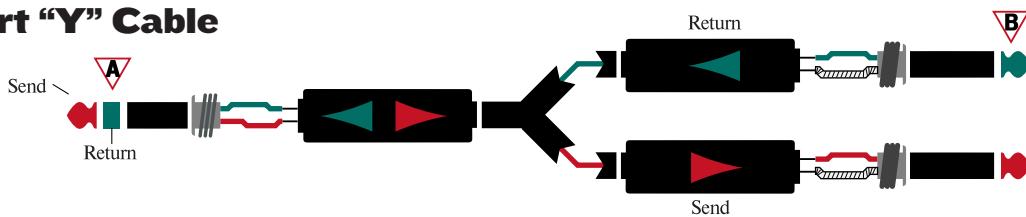

The "Y" Cable is used for connecting serial effects devices, such as graphic equalizers or compressors, to a Mackie mixer's Channel or Bus insert jacks. On one end is a standard Tip-Ring-Sleeve "stereo" plug. Its tip and ring are wired to separate mono Tip-Sleeve plugs. Note that the RING of the TRS plug (A) is actually wired to the TIP of one of the mono TS plugs (B). If you insert a TS (mono) 1/4" plug only partially (to the first click) into an insert jack, the plug will not activate the jack switch and will not break the insert connection in the circuit (thereby allowing the channel signal to continue on its merry way through

the mixer). See (C) in "Insert Points" below.

Partial insertion allows you to tap out of the channel or bus circuit at that point in the circuit without interrupting normal operation.

If you push the 1/4" TS plug in to the second click, you will open the jack switch and create a direct out, which does interrupt the signal in that channel or bus circuit. See (D) in "Insert Points" above. Note: Do not overload or short-circuit the signal you are tapping from the mixer. That will affect the internal signal of the mixer.

Insert Points

TS Plug (mono)



Direct out with no signal interruption to master. Insert only to first "click."

TS Plug (mono)



Direct out with signal interruption to master. Insert all the way in to the second "click."

TRS Plug (stereo)



For use as an effects loop. (TIP = SEND to effects RING = RETURN from effects)

Attention !



You may notice these effects unit hookups (Figure A) throughout this applications guide. These hookups utilize the Insert "Y" Cable (explained on the facing page).

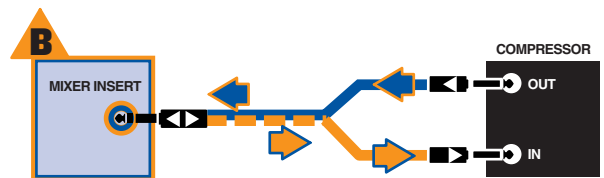

Figure B is a closeup of Figure A. The two colors represent the input and output traveling the length of the "Y" cable. The dotted line represents the two signals travelling alongside one another.



CFX SERIES

CFX-12 SMALL CLUB SET UP

SET UP, AND GO!

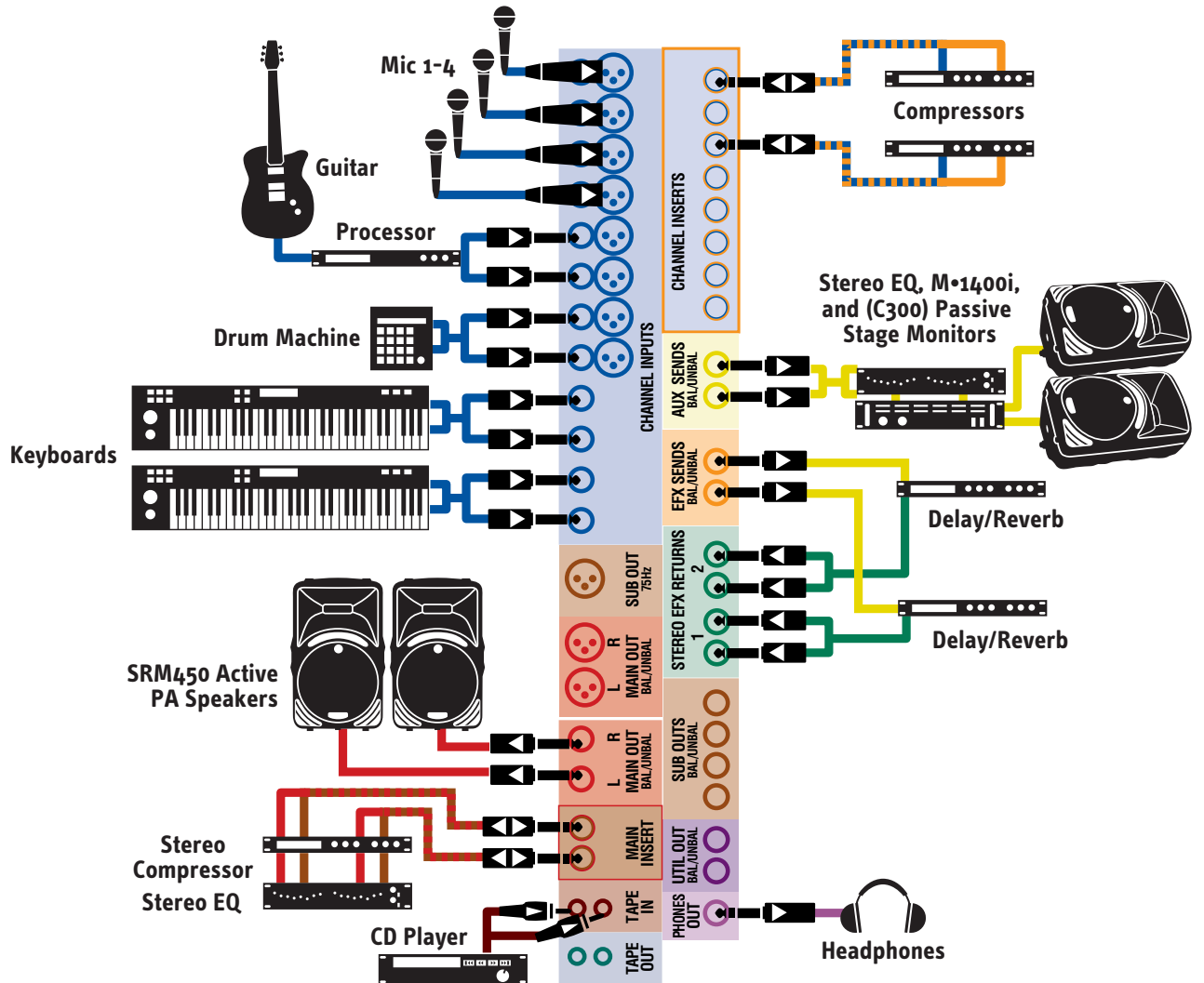



CFX SERIES

CFX-16 LARGE CLUB SET UP

SET IT UP, AND GO!

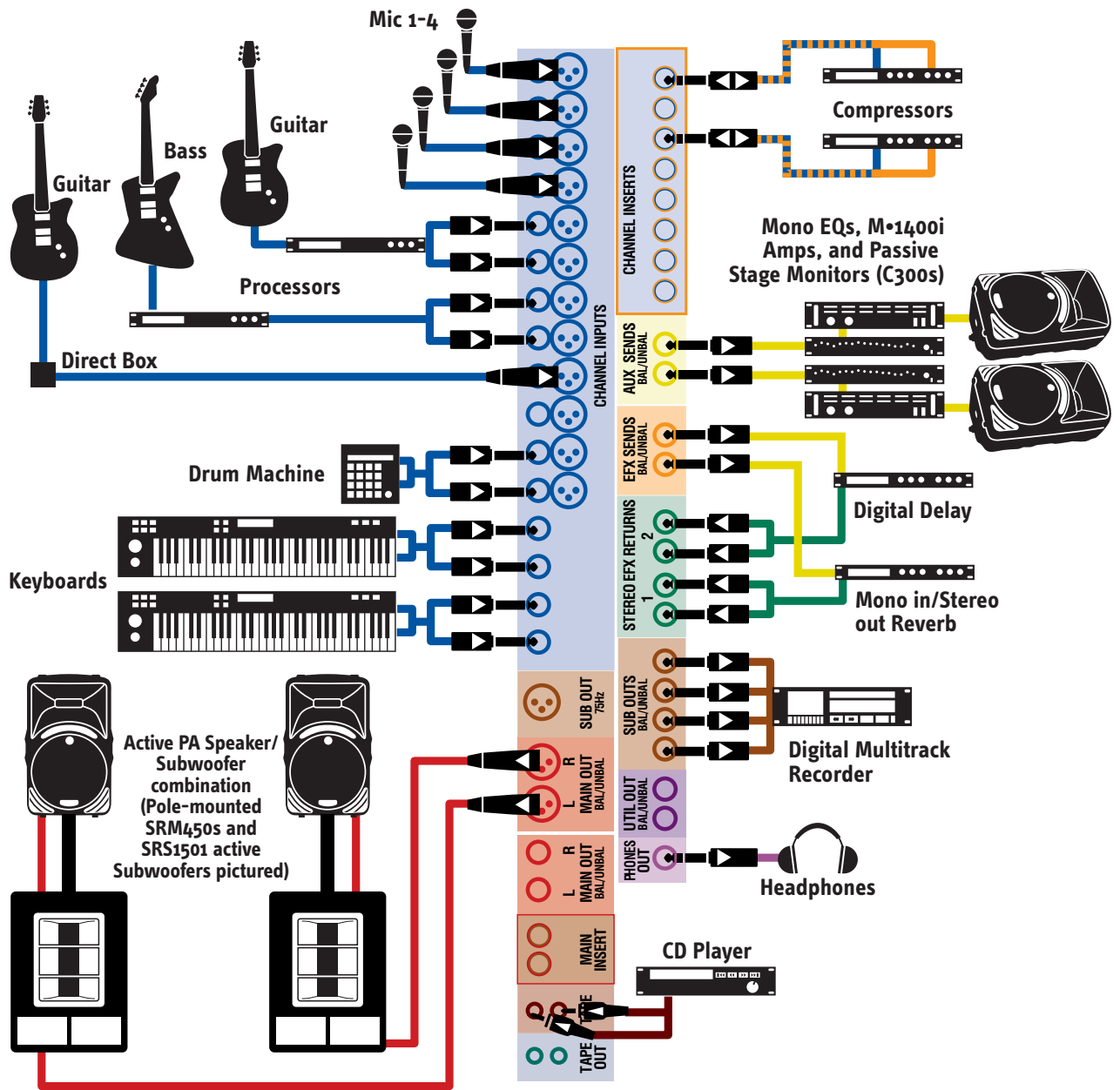



CFX SERIES

CFX-20 CHURCH SET UP

SET IT UP, AND GO!

