 <div style="background-color: black; color: white; padding: 5px; font-weight: bold; font-size: 1.2em;">CAUTION AVIS</div> <div style="text-align: center;"> <p>RISK OF ELECTRIC SHOCK DO NOT OPEN</p> <p>RISQUE DE CHOC ELECTRIQUE NE PAS OUVRIR</p> </div> 
<p>CAUTION: TO REDUCE THE RISK OF ELECTRIC SHOCK DO NOT REMOVE COVER (OR BACK) NO USER-SERVICEABLE PARTS INSIDE REFER SERVICING TO QUALIFIED PERSONNEL</p> <p>ATTENTION: POUR EVITER LES RISQUES DE CHOC ELECTRIQUE, NE PAS ENLEVER LE COUVERCLE. AUCUN ENTRETIEN DE PIECES INTERIEURES PAR L'USAGER. CONFIER L'ENTRETIEN AU PERSONNEL QUALIFIE.</p> <p>AVIS: POUR EVITER LES RISQUES D'INCENDIE OU D'ELECTROCUTION, N'EXPOSEZ PAS CET ARTICLE A LA PLUIE OU A L'HUMIDITE</p>



The lightning flash with arrowhead symbol within an equilateral triangle is intended to alert the user to the presence of uninsulated "dangerous voltage" within the product's enclosure, that may be of sufficient magnitude to constitute a risk of electric shock to persons.

Le symbole éclair avec point de flèche à l'intérieur d'un triangle équilatéral est utilisé pour alerter l'utilisateur de la présence à l'intérieur du coffret de "voltage dangereux" non isolé d'ampleur suffisante pour constituer un risque d'électrocution.



The exclamation point within an equilateral triangle is intended to alert the user of the presence of important operating and maintenance (servicing) instructions in the literature accompanying the appliance.

Le point d'exclamation à l'intérieur d'un triangle équilatéral est employé pour alerter les utilisateurs de la présence d'instructions importantes pour le fonctionnement et l'entretien (service) dans le livret d'instruction accompagnant l'appareil.

SAFETY INSTRUCTIONS

- 1. Read Instructions** — All the safety and operation instructions should be read before this Mackie product is operated.
- 2. Retain Instructions** — The safety and operating instructions should be kept for future reference.
- 3. Heed Warnings** — All warnings on this Mackie product and in these operating instructions should be followed.
- 4. Follow Instructions** — All operating and other instructions should be followed.
- 5. Water and Moisture** — This Mackie product should not be used near water — for example, near a bathtub, washbowl, kitchen sink, laundry tub, in a wet basement, near a swimming pool, swamp or salivating St. Bernard dog, etc.
- 6. Ventilation** — This Mackie product should be situated so that its location or position does not interfere with its proper ventilation. For example, the Component should not be situated on a bed, sofa, rug, or similar surface that may block any ventilation openings, or placed in a built-in installation such as a bookcase or cabinet that may impede the flow of air through ventilation openings.

PORTABLE CART WARNING	
	<p>Carts and stands - The Component should be used only with a cart or stand that is recommended by the manufacturer.</p> <p>A Component and cart combination should be moved with care. Quick stops, excessive force, and uneven surfaces may cause the Component and cart combination to overturn.</p>

7. Heat — This Mackie product should be situated away from heat sources such as radiators, or other devices which produce heat.

8. Power Sources — This Mackie product should be connected to a power supply only of the type described in these operation instructions or as marked on this Mackie product.

9. Power Cord Protection — Power supply cords should be routed so that they are not likely to be walked upon or pinched by items placed upon or against them, paying particular attention to cords at plugs, convenience receptacles, and the point where they exit this Mackie product.

10. Object and Liquid Entry — Care should be taken so that objects do not fall into and liquids are not spilled into this Mackie product.

11. Damage Requiring Service — This Mackie product should be serviced only by qualified service personnel when:

- A.** The power-supply cord or the plug has been damaged; or
- B.** Objects have fallen, or liquid has spilled into this Mackie product; or
- C.** This Mackie product has been exposed to rain; or
- D.** This Mackie product does not appear to operate normally or exhibits a marked change in performance; or
- E.** This Mackie product has been dropped, or its chassis damaged.

12. Servicing — The user should not attempt to service this Mackie product beyond those means described in this operating manual. All other servicing should be referred to the Mackie Service Department.

13. To prevent electric shock, do not use this polarized plug with an extension cord, receptacle or other outlet unless the blades can be fully inserted to prevent blade exposure.

Pour prévenir les chocs électriques ne pas utiliser cette fiche polarisée avec un prolongateur, un prise de courant ou une autre sortie de courant, sauf si les lames peuvent être insérées à fond sans laisser aucune partie à découvert.

14. Grounding or Polarization — Precautions should be taken so that the grounding or polarization means of this Mackie product is not defeated.

15. This apparatus does not exceed the Class A/Class B (whichever is applicable) limits for radio noise emissions from digital apparatus as set out in the radio interference regulations of the Canadian Department of Communications.

ATTENTION — Le présent appareil numérique n'émet pas de bruits radioélectriques dépassant les limites applicables aux appareils numériques de class A/de class B (selon le cas) prescrites dans le règlement sur le brouillage radioélectrique édicté par les ministères des communications du Canada.

<p>WARNING — To reduce the risk of fire or electric shock, do not expose this appliance to rain or moisture.</p>



Lend Me Your Ears

Exposure to extremely high noise levels may cause permanent hearing loss.

Individuals vary considerably in susceptibility to noise-induced hearing loss, but nearly everyone will lose some hearing if exposed to sufficiently intense noise for a period of time. The U.S. Government's Occupational Safety and Health Administration (OSHA) has specified the permissible noise level exposures shown in this chart.

Duration Per Day In Hours	Sound Level dBA, Slow Response	Typical Example
8	90	Duo in small club
6	92	
4	95	Subway Train
3	97	
2	100	Very loud classical music
1.5	102	
1	105	Patrice screaming about deadlines
0.5	110	
0.25 or less	115	Loudest parts at a rock concert

According to OSHA, any exposure in excess of these permissible limits could result in some hearing loss. To ensure against potentially dangerous exposure to high sound pressure levels, it is recommended that all persons exposed to equipment capable of producing high sound pressure levels

(such as this amplification system) use hearing protectors while this unit is in operation. Ear plugs or protectors in the ear canals or over the ears must be worn

when operating this amplification system in order to prevent a permanent hearing loss if exposure is in excess of the limits set forth here.

INTRODUCTION

Thank you for choosing a Mackie Designs power amplifier! We appreciate your vote of confidence for the folks in Woodinville who specialize in awesome and affordable audio. The Mackie Designs M•800 power amplifier is designed to fulfill the amplification needs of almost any type of application. It boasts a wealth of features you'd expect to pay extra for — like low cut filtering, constant directivity equalization, speaker-protecting limiter, and ultra-clean power, to name a few.

Perhaps the most important feature of the FR Series™ power amplifiers is the attention to detail in every aspect of the design. At Mackie, we know what it takes to be roadworthy. After all, our equipment has traveled all over the world under the worst of conditions, and we've applied what we've learned to the mechanical design of our amplifiers.

Roadworthiness is only part of the picture. We know that reliability is paramount to sound reinforcement. That's why we use double-sided thru-hole-plated fiberglass printed circuit boards. That's why our engineers have subjected the amplifier to the most rigorous and fiendish tests imaginable, to fine-tune the design and extend its limits beyond those of ordinary amplifiers.

Fast Recovery — where the "FR" comes from — is more than a buzzword. It is based on real, proven design principles. The result is an amplifier that performs better than conventional designs when presented with adverse conditions. One of the most difficult things for a power

amplifier to handle is clipping. Conventional designs use lots of negative feedback to provide stability and lower distortion. When clipping occurs, this "feedback" causes high-frequency sticking, keeping the amplifier "latched" in the clipping state longer than necessary. This results in painfully audible distortion. Our Fast Recovery design eliminates this high-frequency sticking and allows the amplifier to remain stable when powering highly reactive loads at high volume levels.

You may wonder why a power amp even needs an owner's manual. After all, you just plug in a few cables and power it up. Well, it's almost that simple. There's just a few things that we'd like you to be aware of, and we'll discuss those right away — please see the **Quick Start** on the next page.

Then go ahead and read the entire manual. The M•800 amplifier has a wealth of useful features, and each of them is explained in loving detail.

Please write your serial number here for future reference (i.e., insurance claims, tech support, return authorization, etc.):

Purchased at:

Date of purchase:



QUICK START

INSTALLATION



You can mount the M•800 amp in any standard rack system (see page 18), or place it horizontally on a floor or table.



Note: 4 ohms is the minimum impedance you should connect to the amplifier in BRIDGE mode and 2 ohms is the minimum per side for STEREO.

If you connect lower impedance speakers, the amplifier may overheat and shutdown.

DO NOT BLOCK THE VENTILATION PORTS. The M•800 draws its ventilation air in from the front and out through the side panels. It needs plenty of fresh air to stay cool.

CONNECTIONS AND SETTINGS

1. Be sure the POWER 4 switch is off before making connections.
2. Turn the GAIN 1 controls fully down (counterclockwise) for now.
3. Set both LOW CUT FILTER 9 controls to their TYPICAL marks (35Hz).
4. Set both CONSTANT DIRECTIVITY 11 switches OFF (unless you're using constant directivity horns with compression drivers).
5. Turn the LIMITER 13 switch ON to provide protection against clipping.

6. Determine which AMP MODE 12 is best for your application:
 - STEREO mode (separate left and right inputs, separate left and right outputs) is the typical setup for amplifying stereo signals.
 - MONO mode (sometimes called Dual-Mono mode — one or two inputs, two mono outputs) is for sending the same signal to two different speakers, with separately-adjustable level controls.
 - BRIDGE mode (sometimes called Bridged-Mono — one or two inputs, one mono output) uses both sides of the amp to power one speaker. An M•800 power amplifier in BRIDGE mode delivers 800 watts (into 4 ohms).
7. In STEREO mode, connect line-level cables from your mixer or preamplifier to the INPUT 7 jacks, either XLR or TRS:
 - The balanced XLR inputs are wired
 - pin 2 = hot (+)
 - pin 3 = cold (-)
 - pin 1 = shield (ground).
 - The 1/4" TRS inputs are wired
 - tip = hot (+)
 - ring = cold (-)
 - sleeve = shield (ground)They can accept either balanced (TRS) or unbalanced (TS) cables.
 - The XLR and TRS inputs for each channel are internally wired in parallel.
8. In BRIDGE mode, connect an input cable to CH 1 or CH 2 INPUT or both.

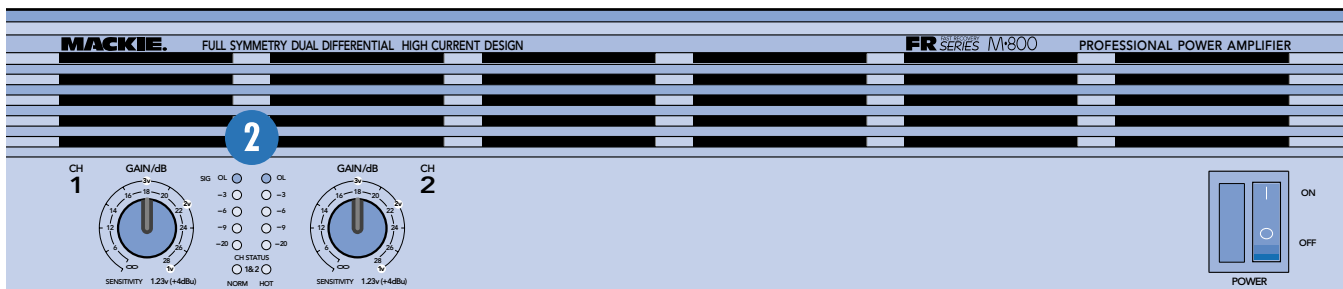

9. In STEREO and MONO, connect speaker cables to the **SPEAKER OUTPUTS 5**, either binding post or 1/4" TS:
 - The binding posts are wired red = positive (+) and black = negative (-)
 - The 1/4" TS connectors are wired tip = positive (+) and sleeve = negative (-)
10. In **BRIDGE** mode, using a single speaker:
 - The speaker positive (+) connects to CH 1's red binding post.
 - The speaker negative (-) connects to CH 2's red binding post.
 - Plug nothing into the black posts or the 1/4" speaker output jacks.
11. Plug the amp's power cord into the IEC receptacle **6** and the other end into a 3-prong AC outlet capable of delivering at least 12 amps (US model).
12. Make sure the signal source feeding the M•800's inputs is powered up and delivering signals to the amp.
13. Turn the M•800's **POWER 4** switch on and verify that the **NORM 3** Channel Status LED is on.
14. Slowly turn both **GAIN 1** controls up: You should now hear the lovely music.
15. If the topmost LEDs (named OL, for OverLoad) are flashing, turn down either the **GAIN** controls on the amp or the source signal's level controls (e.g., master faders). The point is: The OL LEDs should not light continuously in normal use.

16. For quieter listening, it is preferable to adjust the amp's **GAIN 1** controls rather than the source signal's output level (unless you have the source's control all the way up!)



Things to Remember:

- Never connect the amplifier speaker outputs into anything except speakers (unless you have an outboard box specifically designed to handle speaker-level signals).
- Read and follow all the safety information shown on page 2 before using the amplifier.
- Turn the amplifier off before making any connections, reconfiguring cables or setting the rear panel switches.
- When you shut down your sound system, turn off the amplifiers first.
- When powering up your system, turn on the amplifiers last.
- Keep the load above 2 ohms for stereo and 4 ohms for bridge operation.
- Keep the **LIMITER 13** ON for most applications.
- Make sure the OL lights do not come on very often. Turn down the amplifier or mixer/preamp gain if they do. Failure to do this may lead to the amplifier overheating, speaker distortion and damage.
- Save the shipping boxes! You may need them someday, and you probably don't want to have to pay for them again.

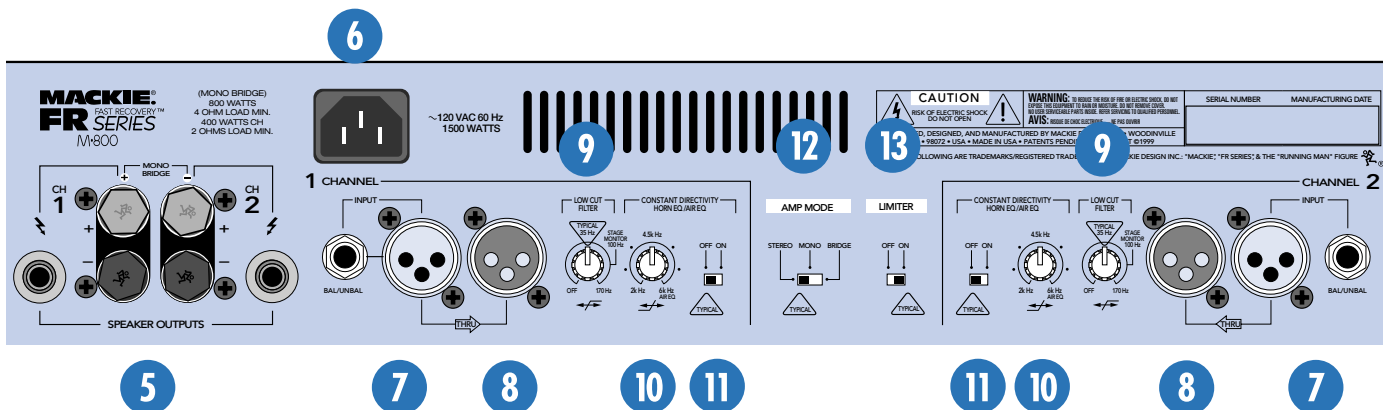

CONTENTS

QUICK START	4
APPLICATION DIAGRAMS	7
FEATURE DESCRIPTIONS	10
1 GAIN	10
2 METERS	11
3 CHANNEL STATUS	11
4 POWER	11
5 SPEAKER OUTPUTS	12
6 POWER CORD	12
7 INPUT	13
8 THRU	13
9 LOW CUT FILTER	14
10 CD FREQUENCY	15
11 CONSTANT DIRECTIVITY	15
12 AMP MODE	16
STEREO	16
MONO	16
BRIDGE	16
13 LIMITER	17
GENERAL PRECAUTIONS	18
RACK MOUNTING	18
THERMAL CONSIDERATIONS	18
AC POWER CONSIDERATIONS	18
INPUT WIRING	19
OUTPUT WIRING	19
APPENDIX A: Service Info	20
WARRANTY SERVICE	20
TROUBLESHOOTING	20
REPAIR	21
APPENDIX B: Technical Information	22
OHMS	22
SPECIFICATIONS	23
BLOCK DIAGRAM	25
APPENDIX C: Bi-amping and Tri-amping	26
M•800 LIMITED WARRANTY	27
PRODUCT REGISTRATION CARD	
Attached to back cover	

Don't forget to visit our website: www.mackie.com for more information about this and other Mackie products.

ABOUT THIS MANUAL

APPLICATION DIAGRAMS

Mackie's gang of oppressed illustrator droids have created easy-to-understand diagrams of popular studio and live-sound setups.

FEATURE DESCRIPTIONS:

Each and every knob, switch, and connector on the M•800 power amplifier is explained in depth here. Important and interesting points are noted using these two icons:



This icon marks information that is critically important or unique to the M•800.



This icon leads you to further explanations of features and some practical tips.

GENERAL PRECAUTIONS

This section discusses important things to keep in mind when installing and using the M•800, including rack mounting, AC power, and wiring.

SERVICE INFORMATION

Appendix A provides some troubleshooting ideas and service details.

TECHNICAL INFORMATION

Appendix B is for you tech-heads who like to use a calculator and read specifications.

BI-AMPING AND TRI-AMPING

Appendix C shows how two or three amplifiers can be used in a sound system, with each playing a different frequency range.

LIMITED WARRANTY

Read this to understand the terms of the factory warranty.

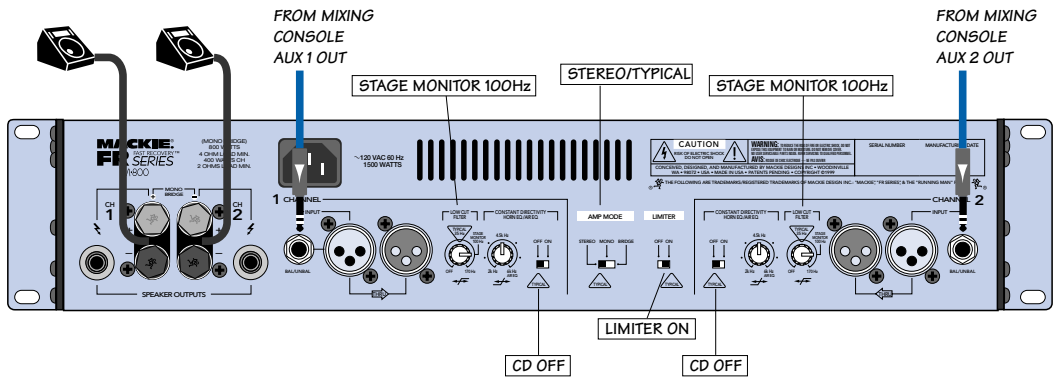
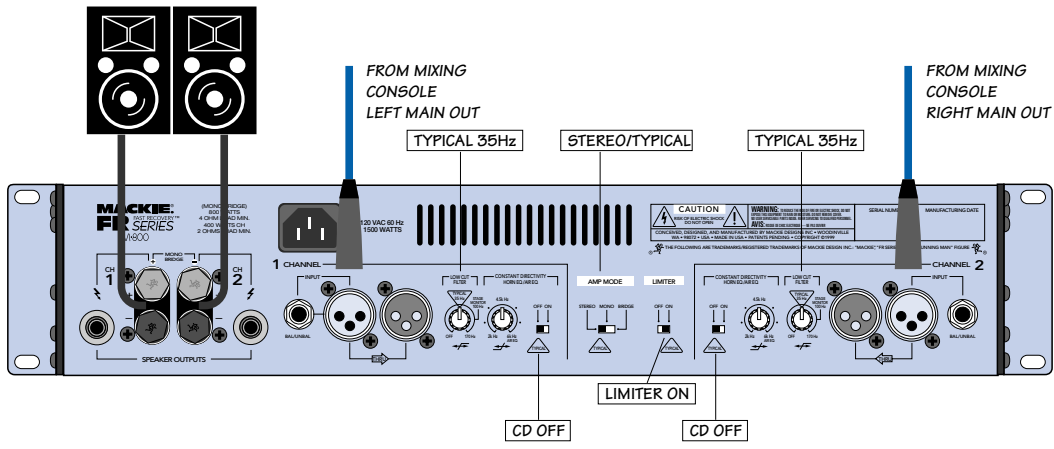

M•800: MAIN SPEAKERS AND STAGE MONITORS

NOTE: IN MONO, CH 1 AND CH 2 INPUT SIGNALS ARE SUMMED, SO YOU CAN USE EITHER INPUT OR BOTH. SET THE CD OR LOW CUT FILTER CORRECTLY ON EACH INPUT YOU USE.

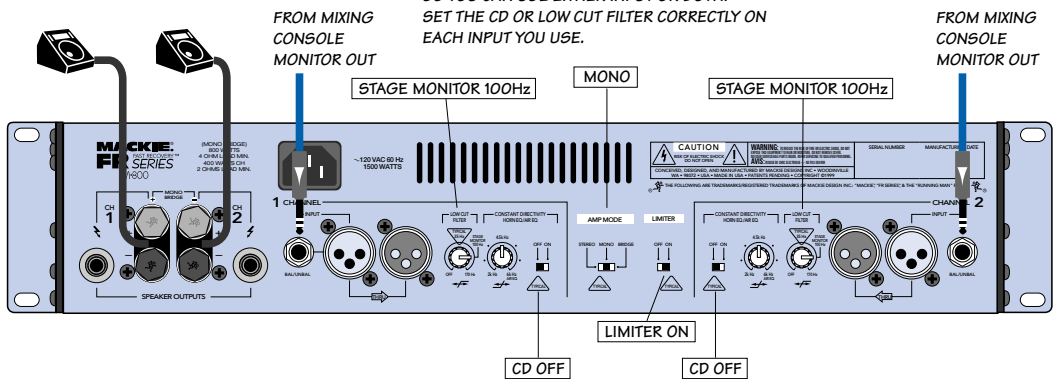

M•800: MONO OPERATION

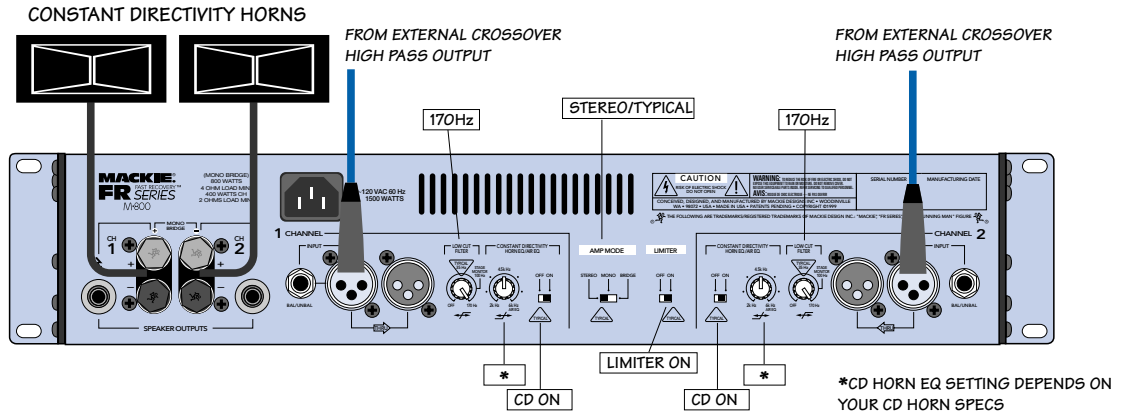
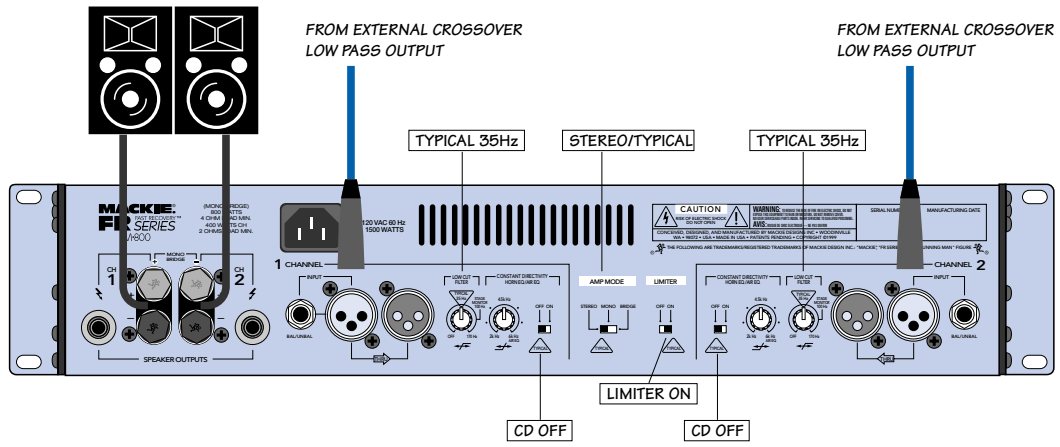

M800: STEREO SYSTEM WITH CD HORNS

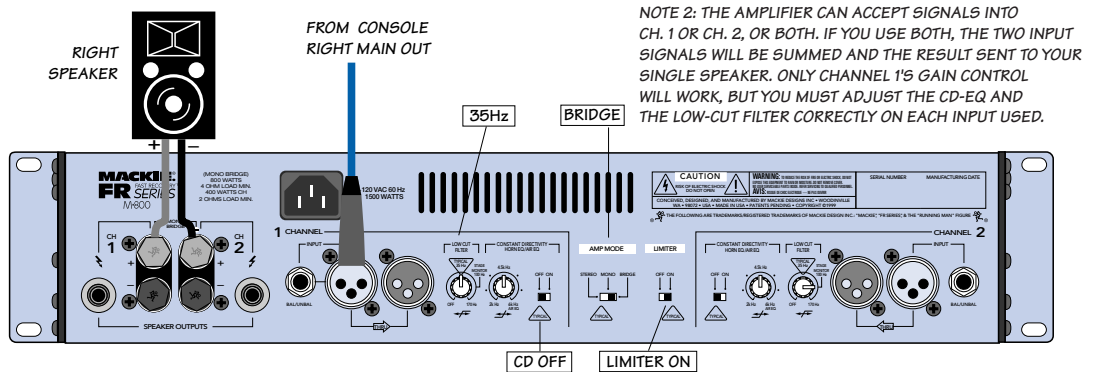
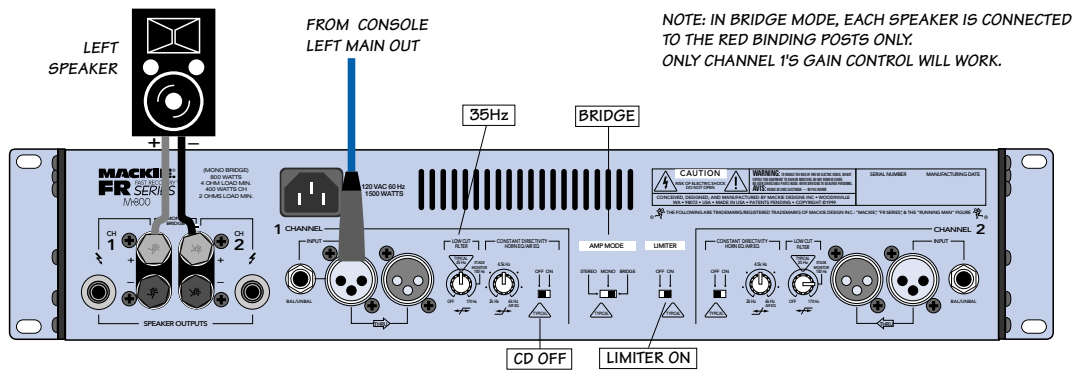

M800: STEREO SYSTEM USING TWO AMPLIFIERS IN BRIDGED MODE

APPLICATION DIAGRAMS

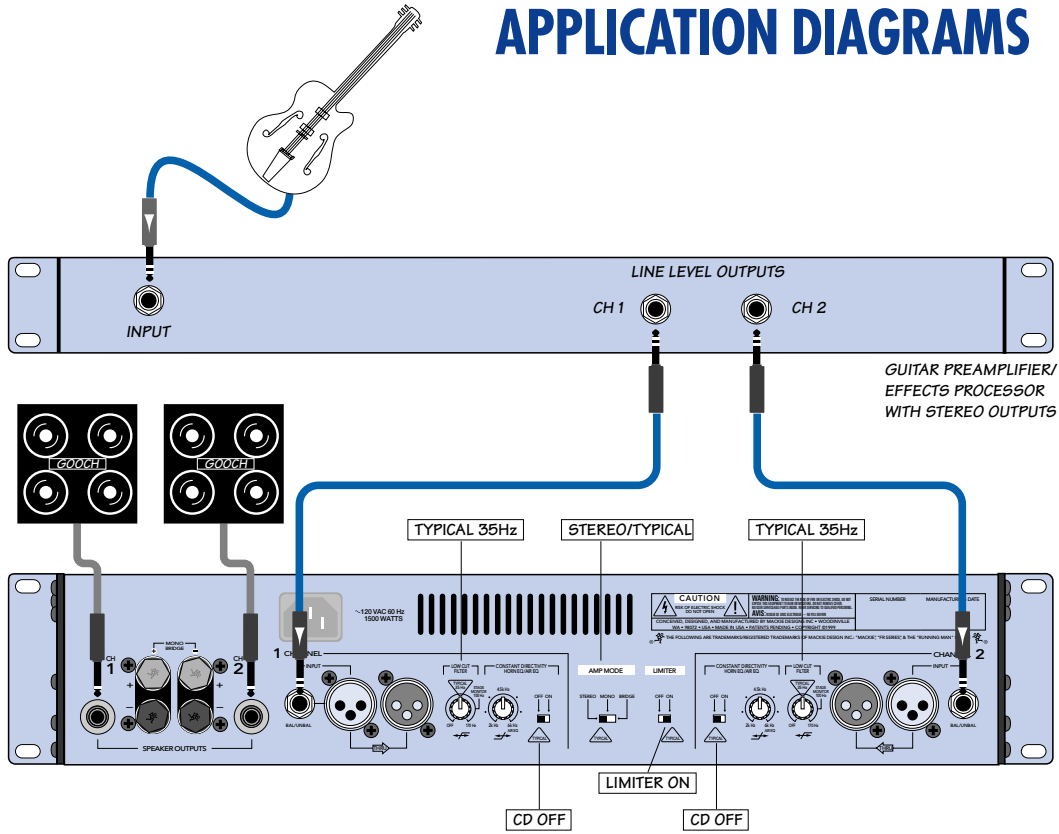

M-800 IN STEREO MODE WITH A GUITAR PREAMPLIFIER/PROCESSOR

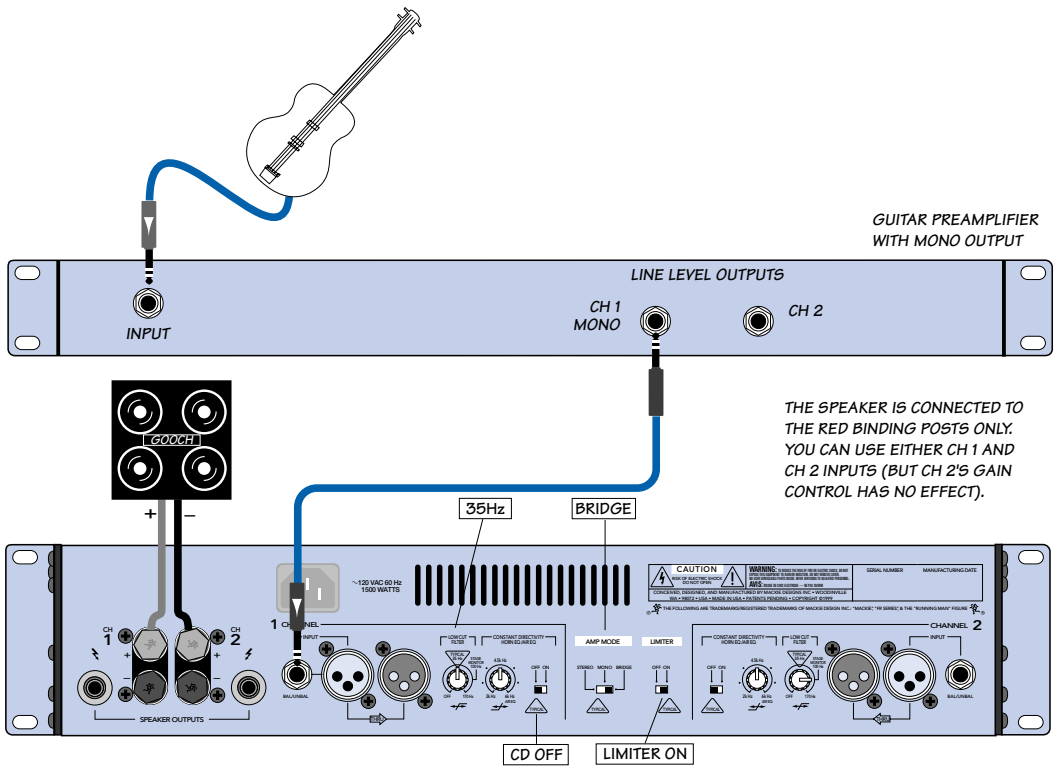

M-800 IN BRIDGE MODE WITH A BASS GUITAR PREAMPLIFIER

FEATURE DESCRIPTIONS

1 LET'S TWIST A GAIN

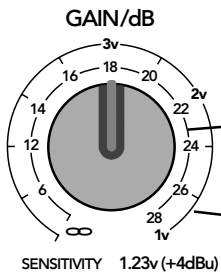

These are completely independent volume controls for each channel. Instead of having an arbitrary scale, they are carefully calibrated:

- The inner ring graphic is labeled in dB, though this indicates the amplifier's voltage gain, think of it as increasing decibels from off to 28.
- The outer ring shows the input sensitivity in volts. This is the amount of voltage required from a mixer to drive the amp to it's rated power output (225 watts into 4 ohms). With the control fully clockwise, it will require an input level of 1.23 volts rms to reach rated power. This is equivalent to putting in a signal level of +4 dBu.

If you have the knob set at 3v, it will require 3 volts from your mixer to reach full power. This will rob the mixer of headroom, because it takes extra voltage to drive the amp. Rotating the knob to 2v means you will need 2 volts from your mixer, which improves the mixer headroom. Rotating the **GAIN** control all the way clockwise provides the best mixer headroom under normal operation.

Note: The calibration marks only apply to stereo or mono operation using speakers of 4 ohms impedance.

Like all amplifier controls, you'll typically determine the optimal settings during installation or sound check, then leave them alone, using your signal source (mixer/preamp) to control listening levels as you work. Or play.

You may wonder why we didn't use just one stereo control to control both sides. That's in case your application requires a left/right imbalance (due to an irregularly shaped room), an irregularly shaped friend, or if you're using the two sides for completely different purposes (such as monitor in CH 1 and side-fill in CH 2).

Here are some more examples of how you might use the **GAIN** controls:

- When you are in a small room where loud volume is not required, having the amp gain controls turned fully clockwise would require you to keep the mixer faders down exceptionally low. In this case, first set the mixer faders to unity gain, adjust the mixer's input trim controls to optimum, then rotate each **M•800 GAIN** control until the desired volume is obtained.

- If you have high efficiency speakers and a high gain preamp, you may hear "hiss" in your speakers. This can be fixed by turning the **GAIN** controls down a few notches.

- If you are not blessed with a mixer or preamp, it is possible to connect a source component directly to the amplifier. For example, you can connect a CD player directly to the inputs. You **MUST** make sure that the amplifier **GAIN** controls are turned down before you start the CD, then bring them up to a nice level. This direct connection only applies to line-level components. It does not apply to turntables, microphones, or instruments, as these need preamplification and equalization.

The **GAIN** controls differ in operation between stereo, dual mono, and bridged modes:

STEREO and MONO:

- Each control is independent;
- CH 1 **GAIN** only changes CH 1,
- CH 2 **GAIN** only changes CH 2.

BRIDGE:

- Only the CH 1 **GAIN** control will work because the CH 2 control is bypassed internally.

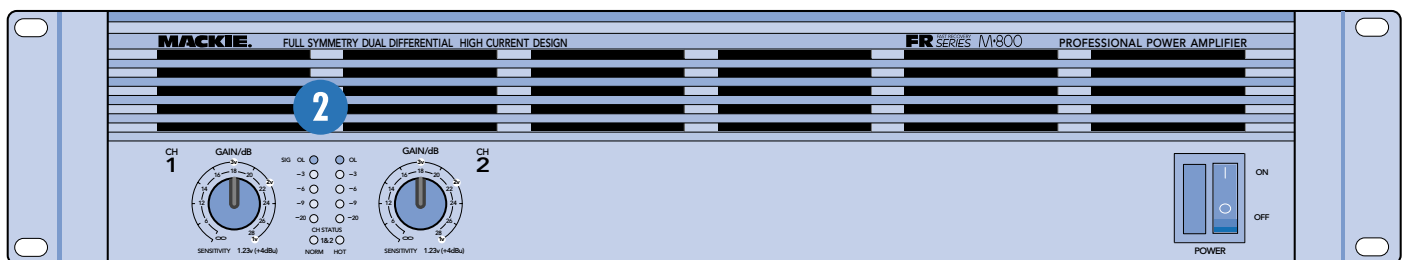

1

3

1

4

2 METERS

The meters indicate the output level in decibels referenced to the clipping point of the amplifier.

The top LED is labeled OL (short for Overload). If this comes on, the amplifier will start to distort, and the audio signals may “clip”.

Ideally, the -20, -9, -6, and -3 LEDs will light at normal signal levels, while the OL LED may blink occasionally during peak moments.

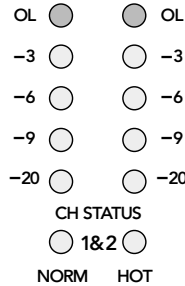

If the OL (Overload) LED is blinking frequently or continuously, turn down the source signal (e.g. the mixer’s master faders or the preamp gain). If this is not done, you may overheat the amplifier and upset the neighbors.

3 CHANNEL STATUS

During normal operation, the NORM LED remains lit, indicating that temperatures within the M•800 are at a safe level. The internal 2-speed cooling fan will run at slow speed.

If the internal temperature of the amplifier rises to 60°C, the fan kicks into high speed, moving more air through the amplifier to cool the output transistors.

If the temperature rises to an unsafe level (85°C), the HOT LED lights and both outputs of the overheated amplifier will mute. The fan will remain running at high speed until the internal temperature drops to 60°C. When this occurs, the NORM LED lights, and the amplifier speaker outputs become active again.



Be Aware: If the HOT LED comes on frequently, something is overworking the M•800 or it’s not properly ventilated. Look at each of the conditions below and

determine what is causing the amplifier to overheat.

- Improper ventilation
- High ambient temperatures
- Overdriving the amplifier into clipping
- Driving hard into low impedance loads
- Frayed or partially shorted speaker cables
- Defective or internally shorted speakers



DO NOT BLOCK THE VENTILATION PORTS. The amplifier fan draws air from the front and out through the side panels. The amp needs plenty of

fresh air to stay cool.

The heaviest load the M•800 can tolerate is 2 ohms per channel (4 ohms in bridged mode). If you have a set of speakers wired in parallel, be sure the load isn’t adding up to less than 2 ohms. Anything below 2 ohms can trigger the protection circuits.

The NORM and HOT LEDs are only affected by the temperature, not by any other fault.

4 POWER

To make the amp operate, push the top half of the POWER switch. It clicks into place and a soothing green light adjacent to it glows. To turn the amp off, push the lower half. It’ll click again and the green light will extinguish.



When you turn on the M•800, a built-in delay circuit prevents any pops or thumps from being transmitted to the speakers.

Although the delay will help, you should still follow these precautions:

- When powering up your system, turn on the amplifiers last.
- When turning off your system, turn off the amplifiers first.
- Make sure that you turn down your signal source, mixer or preamp before you turn on the amplifier.
- If you have multiple amps, you should turn them on one at a time. This will prevent blowing a circuit breaker if they all come on at the same time.

6 POWER CORD

The M•800 is supplied with a detachable power cord. Make sure the power switch is off before firmly attaching the cord to the amplifier. Fit the other end into an AC outlet properly configured for the type of plug on the power cord and for the voltage rating of the amplifier.

For current-delivery purposes, the M•800's voltage source (wall outlet, extension cords, or power strips) must be capable of continuously delivering 12 amps (US model). And for safety reasons, that source must be a "3-prong" outlet with hot, neutral, and ground terminals. We're dealing with some big-time electricity here — don't mess with it. See "AC Power Considerations" on page 18.

5 SPEAKER OUTPUTS

To use the binding post outputs, you can terminate your speaker cables with single or dual banana plugs, or bare wire.

To use banana plugs:

First pull off the small plastic end caps from each of the binding posts to reveal the holes. It is important to hand-tighten each post before plugging in the bananas.

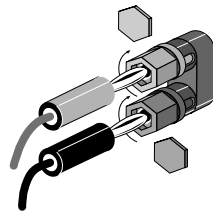

To use bare wire:

Unscrew the amp's binding posts, insert your stripped wires (stripped about 3/8" back) into the side holes and retighten the posts (finger tight is fine — do not use a wrench!). Be careful that no wire strands touch the chassis or other terminals.

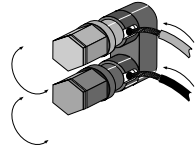

The red posts are labeled "+," which means positive, and the black posts are labeled "—" for negative. The amplifier is "common grounded," that is, both black posts are connected internally to ground.

Use high-quality speaker cable (16 gauge or thicker) to connect the positive outputs of the M•800 to the speaker's positive inputs, and the negative outputs to the speaker's negative inputs. You probably know the importance of getting these connections correct — if one side is hooked up "out of phase," this will cause a reduction in the bass output and your pay.

If you're using the M•800 in BRIDGE mode, the speaker connects across the red posts only (see page 16 for details).

In addition to the binding posts, the M•800 has 1/4" TS (tip-sleeve) outputs, so you can use speaker cables with 1/4" TS plugs. The tip is positive (+) and the sleeve is negative (-). They're wired in parallel with the binding posts and behave exactly the same (except they can't be used in BRIDGE mode).

You can use both the 1/4" jacks and the binding posts simultaneously. Just remember that doing so creates two parallel loads.



Be Aware: Should you choose to terminate your speaker cables with 1/4" TS plugs, make sure nobody confuses these cables with line-level

cables, (i.e., guitar cords). *Guitar cords are not designed to handle the high current output of power amplifiers.*

Furthermore, line-level inputs (like the signal input on a mixer) are not designed to handle speaker-level voltages. The results are not pretty, and can ruin a mixer technician's whole day.

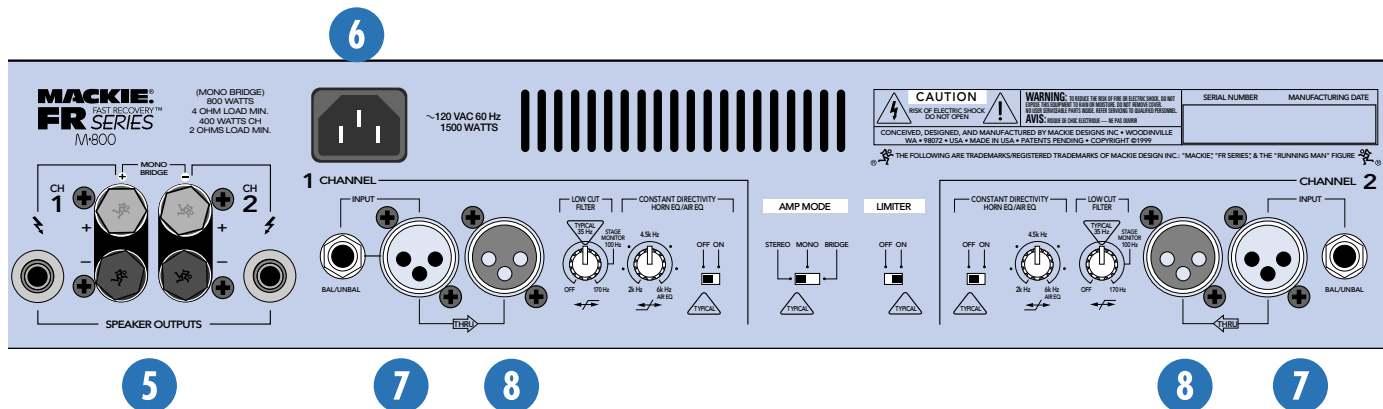



If you're using low impedance loads at high power levels, we recommend that you use the binding post speaker outputs rather than the 1/4" TS jacks. Although 1/4" jacks and plugs are convenient and easy to use, they are not designed to handle high-level currents.

Make sure that the amplifier is off before making connections or reconfiguring the signal routing.

Make sure that the amplifier is off before making connections or reconfiguring the signal routing.

7 INPUT

The M•800 gives you a choice of inputs — it has XLR as well as 1/4" TRS (Tip-Ring-Sleeve) input jacks. Sonically (and electrically) they're identical, so choose either one. Since these two inputs are in parallel, don't use both at the same time.

The amplifier expects to see a nominal signal level anywhere between the -10 dBV "semipro" and +4 dBu "pro" standards, meaning almost any line-level mixer or other device can be plugged into the amp's INPUTs. Use the GAIN controls to adjust the gain of the amplifier to match the signal level you're using.

Each type of input can be used with either balanced or unbalanced signals.

Balanced

Use the balanced connections if your source has balanced outputs. This will greatly reduce any noise picked up in your system.

When connecting a balanced signal using the XLR or 1/4" jacks, they're wired thusly, per AES (Audio Engineering Society) standards:

	<u>XLR</u>	<u>TRS</u>
Hot (+)	Pin 2	Tip
Cold (-)	Pin 3	Ring
Shield (Ground)	Pin 1	Sleeve

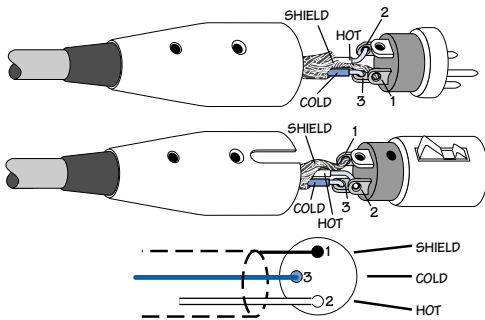

Balanced XLR Plug (prior to Lunar orbit insertion)

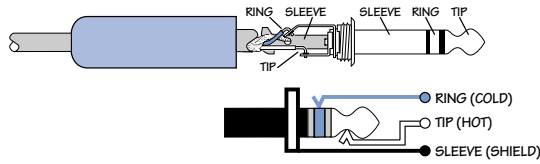

Balanced 1/4" TRS Plug

Unbalanced

Unbalanced TS (Tip-Sleeve) lines can be accommodated via the TRS jack. Make sure the cord terminates with a TS plug (like a guitar plug), or if it's a TRS plug (like a headphone plug), make sure the ring is tied to the shield, preferably at the source end.

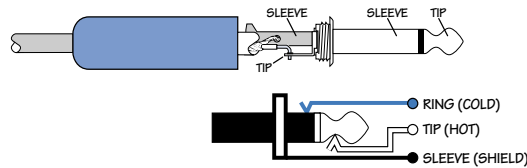

Unbalanced 1/4" TS Plug

8 THRU

The THRU jacks allow you to feed the input signal to the inputs of other amplifiers. In this way, multiple amplifiers can receive an input signal from your single mixer or preamp. This is accomplished as follows:

- Make sure all your equipment is turned off before making any connections.
- Plug the signal source outputs into the first amp's INPUTs.
- Patch from that amp's THRU jacks to the next amp's INPUT, and so on, daisy-chaining to other amps in your system (assuming your mixer has low impedance outputs).



To prevent excessive loading of your source, a general rule of thumb is to maintain a load impedance 10 times or more than the source impedance. If your console has an

output impedance of 100 ohms, then you can daisy-chain up to twenty M•800 amplifiers, which presents a load of 1000 ohms to the console (input impedance of 20 kohms divided by 20 amplifiers = 1000 ohms).

The THRU jacks can also be used to relay the input signals on to other devices such as a DAT or cassette recorder. They are wired in parallel with the XLR and TRS INPUTs, so the signals coming out of the THRU jacks are exactly the same as the signals going into the amp, unaffected by any of the amp's switches and controls.



You can use the THRU jack as an input, if necessary, since it's wired in parallel with the other input connectors.

You can also use the 1/4" TRS INPUT jacks as THRU jacks. Simply connect the 1/4" TRS INPUT jacks on the first amplifier to the TRS 1/4" INPUT jacks on the second amplifier using 3-conductor shielded cables with TRS plugs on both ends.



Warning: If you are using a balanced input to the first amp, do not use TS unbalanced connections to feed other amplifiers. This will unbalance the input connections of your first amp by grounding pin 3.

connections of your first amp by grounding pin 3.

9 LOW CUT FILTER

Every woofer has frequency response specifications. It's usually expressed in Hertz (or cycles per second), like "40Hz–300Hz." The "40Hz" refers to the low-frequency point (usually, but not always) where the speaker's output drops by 3 dB, and will "roll off" completely as the frequency goes down. There is no point in sending a woofer any frequencies it can't reproduce — you can't hear it, and worse yet, it's a waste of amplifier power that can be better used reproducing frequencies you *can* hear.

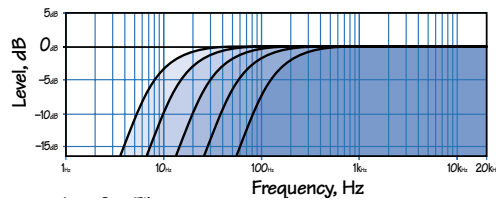

Low Cut Filter Frequency Response

In order to match the output bandwidth with your particular speaker system, the M•800 amplifier has a tunable LOW CUT FILTER. The frequencies are clearly marked along the knob's travel:

- Fully counterclockwise, the frequency is below 10Hz, effectively bypassing the filter.
- Center detent is 35Hz, labeled TYPICAL, since few woofers actually go below that.
- 3/4 of the way up is labeled STAGE MONITOR, 100Hz, perfect for, well, stage monitors (they seldom reproduce below 100Hz; besides, it prevents low frequency "leakage" into the house).
- Fully clockwise is labeled 170Hz.

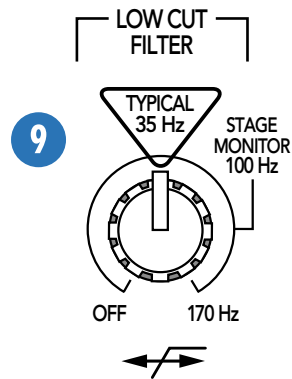

So, grab your woofer's spec sheet and find the low roll-off spec. Then set the M•800's LOW CUT FILTER at the same frequency.

If you do this correctly (and make sure the meters are happy), you'll never again see your woofer moving sporadically without audible signal. Your system will play louder and cleaner, and you may never blow another woofer again!

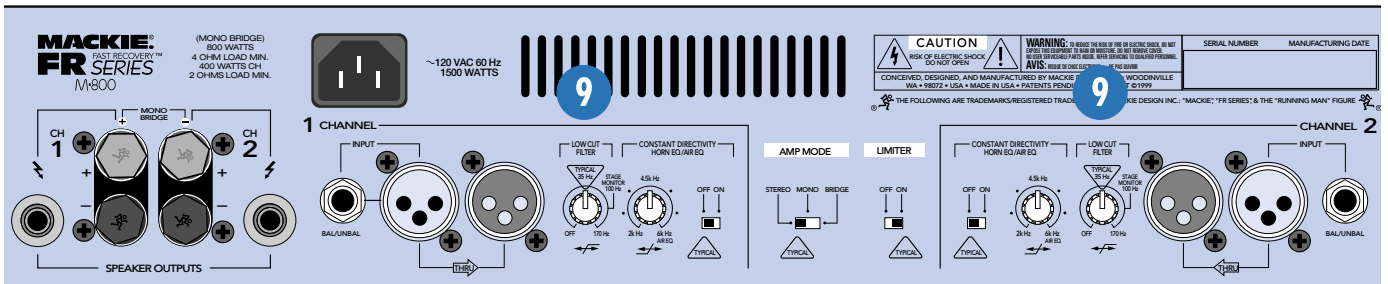

11 CONSTANT DIRECTIVITY SWITCH

If you don't have constant directivity horns, you can leave this switch OFF.

Compression drivers mounted on constant-directivity horns require compensation in the form of a high-frequency boost, with its "knee" set somewhere between 2kHz and 6kHz. Until now, you'd have to resort to external crossovers or worse yet, graphic EQ modules. Both of these are fraught with limitations, not to mention adding cost, rack space requirements, and complexity to your system.

The M•800 power amplifier eliminates the need for any of these external devices — it has the compensation circuitry already built in, and using it is a breeze.

10 CD FREQUENCY

Your compression drivers' spec sheet should have a suggested frequency for compensation boost. If so, just turn the **CONSTANT DIRECTIVITY** switch ON and set its knob to match that frequency. If your spec sheet doesn't have that information, you can simply adjust the frequency knob by ear, preferably using the same music as the actual performance (3.5kHz is a good place to start).

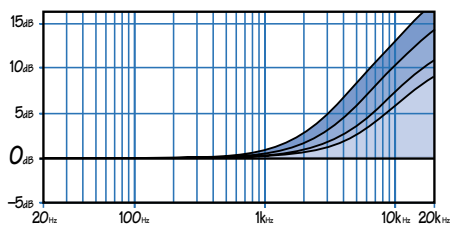

Constant Directivity EQ

Even if you don't have CD horns, you can use the **CONSTANT DIRECTIVITY** feature to enhance your EQ curve. By setting the frequency knob fully clockwise, you introduce a very high-frequency boost to the signal (above 6kHz). And in Mackie-land, this gentle boost has a name: **AIR**, as seen on our SR series of consoles. By boosting these high frequencies, **AIR** will breathe life into your mix, making cymbals brighter and vocals silkier.

Speaking of Mackie SR consoles: If you use the **AIR** feature on an SR console as well as the **AIR** feature just described on the M•800, you may be overdoing it. You won't hyper-ventilate or anything, but it might cause your audience to experience ear fatigue from too much high-frequency content. Too much of a good thing, perhaps.

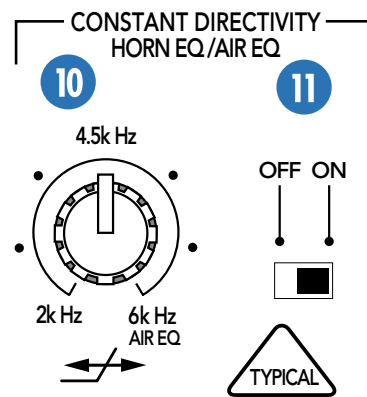

More on Constant Directivity Horns

All high-frequency compression drivers have an inherent roll-off of about 6 dB per octave above about 3kHz. The exact frequency at which the roll-off occurs (called the mass breakpoint) depends on the materials used, the mass of the moving parts (diaphragm and voice coil) and the strength of the magnet. The **CONSTANT DIRECTIVITY HORN EQ** control on the M•800 compensates for this natural roll-off in the power response of the compression driver coupled to a CD horn, with the end result of flat-frequency response (constant) over a wide coverage angle (directivity).

12 AMP MODE

This three-way switch determines what kind of amplifier you want the M•800 to be (or not to be — what was the question?)

The switch alters the input signal routing within the amplifier. Shipped from the factory, it is set to **STEREO**, correct for about 90% of applications (hence the **TYPICAL** indicator near it).

The switch should only be configured when the amplifier is turned off.

STEREO

This is the typical setup for amplifying stereo signals. There are separate left and right inputs, and separate left and right outputs. The two channels are independent of each other.

MONO

This mode (also known as Dual-Mono) is used to send the same signal to each speaker.

- There are one or two inputs and two mono outputs.
- You can feed either channel or both.
- The inputs are summed (before the **GAIN** controls) and the mix sent to both amplifier channels.
- The **GAIN** controls are still independent.
- The speakers are connected as for normal stereo use.

BRIDGE

In **BRIDGE** mode (also known as Bridged-Mono) the two channels of the M•800 are combined internally and can deliver up to 800 watts into a single 4 ohm speaker.

- There are one or two inputs and one mono output.
- You can feed either channel or both.
- **CH 2's GAIN** control will have no effect.
- The amplifier channels are internally combined in series.
- Only one speaker is used and it is connected in a special way. Read on.

Some examples of using the **BRIDGE** mode:

- Two M•800s can be used to create a powerful stereo system, each driving one speaker.
- You can use one amp to power a mono system, such a center speaker or PA.
- Multiple M•800s can be used in theater surround systems, each driving one speaker.

To use the M•800 in **BRIDGE** mode:

1. Turn off the power.
2. Set the **AMP MODE** switch to **BRIDGE**.
3. Connect the positive side of the speaker cable to the CH 1 red (+) binding post.
4. Connect the negative side of the speaker cable to the CH 2 red (+) binding post.
5. Use only the CH 1 **GAIN** control.
6. The M•800 black binding posts are unused.



WARNING: In **BRIDGE** mode, both connections to your speaker are live; that is, neither is grounded through the chassis (because the M•800 black binding posts are not used).

Take great care to read and follow all safety instructions. The M•800 is capable of up to 85V AC across the speaker terminals.

Note: The calibration scales of the **GAIN** control only apply when using 4 ohm speakers.

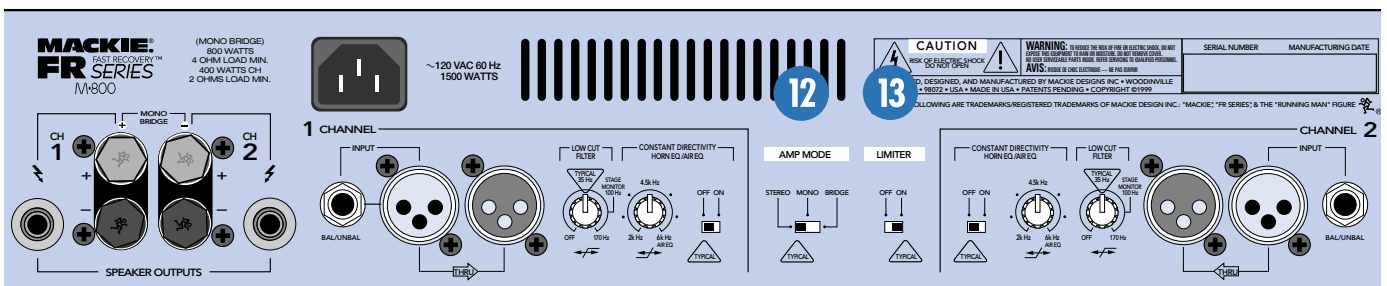

13 LIMITER

LIMITER ON (TYPICAL). This is the normal configuration with protective limiting.

LIMITER OFF is without protective limiting.

The limiter is not designed to alter your sound — it's just there to protect your speakers from the effects of clipping. Its effect is virtually transparent, meaning you probably won't even notice any audible difference. We recommend that you leave it engaged, hence the **TYPICAL** label below it.

If you're working at quiet levels all the time, or you've already placed a compressor/limiter in the signal path, or if you just hate compression, you can leave the limiter out of the circuit. By design, the limiter is out of circuit when not called upon.

The limiter works independently on each channel. It senses when the amplifier channel is about to be overdriven and attenuates the overall level just enough to keep the signal from clipping. Clipping occurs when the output voltage no longer linearly follows the input voltage and simply stops. This causes a sine wave to "square off," and the average power going into the speaker is roughly double that of a sine wave. Square waves sound awful, and could possibly damage your speakers and/or your reputation.

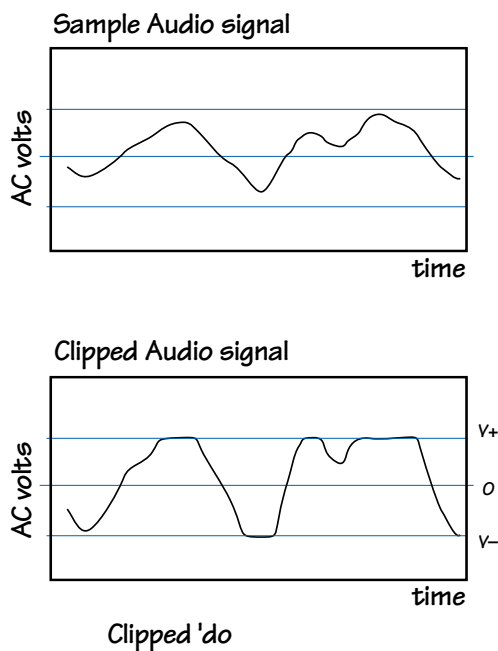

As the amplifier output voltage increases, it will eventually run into the internal DC power supplies and start to flatten out. The flat tops represent a DC voltage reaching your speakers, which interrupts the natural movement of the speaker's voice coil. High frequency harmonics are also produced which can play havoc with your tweeters.

Speakers are designed to handle good clean continuous signals, but give them a clipped signal and even high powered speakers can be damaged. For example, a 100 watt amplifier that is clipping, can damage speakers that are rated at 400 watts.

The limiter is especially handy when you're working with loud output levels. Having the signal spikes (kick drum, for instance) attenuated a bit can actually increase the apparent loudness of the overall mix without diminishing the "power" behind the spikes.

It is also a useful protection device for those unexpected moments, such as a mike stand falling over, dropping the tone arm, or an attack of killer feedback.



Be Forewarned: With the limiter engaged, you can still overdrive the amplifier into clipping and cause distortion. It just takes a stronger signal to do it. So even with the **LIMITER** turned on, you *must* pay attention to the **OL LEDs**.

GENERAL PRECAUTIONS

RACK MOUNTING

The M•800 amp requires two rack space units (2U = 3.5"). It also requires 16.25" depth inside the rack, including the rear supports. When designing your rack, put the heavier items at the bottom and the lighter items toward the top.

Secure the front panel of the amplifier to the front of the rack using four screws with soft washers to prevent scratching the panel. In addition, because of the weight of the amplifier, you must secure the rear support brackets of the amplifier to the back of the rack. You could use a support rail or shelf across the back of the rack, or angle brackets attached between the rear support brackets and the rear rails of the rack. This is recommended for all components mounted in a rack that is going to be moved frequently.

THERMAL CONSIDERATIONS

The M•800 amp is fan-cooled and brings air in through the front and out through the sides. Make sure that cool air is available at the front of the amplifier, and that there is room on each side for the warm air to exit from the amplifier and dissipate. If rack-mounted, make sure there is room for the warm air to circulate around the side and out through the rear of the rack. In a typical rack, there will be a space of 1 to 2 inches on either side of the amplifier. This is adequate to allow the warm air to exit from the amplifier.

AC POWER CONSIDERATIONS

Be sure the M•800 is plugged into an outlet that is able to supply the correct voltage specified for your model. If the voltage should drop below 97% of line voltage, the M•800 will no longer be able to supply rated power. (It will continue to operate down to 65% of the rated voltage, but it won't be able to reach full rated power). The amplifier will mute if the voltage drops below 65% of the rated voltage. This could happen if you use a long extension cord, reproducing music with large peaks.

Be sure the AC outlet can supply enough current to allow full power operation of all the amplifiers plugged into it. The outlet should be a three-prong socket that matches the power cord.



WARNING: Bypassing the plug's ground pin can be dangerous. *NEVER do it!*

The AC current demand of an amplifier varies depending on several factors, including the crest factor and the duty cycle of the program material. Under typical conditions reproducing rock music where musical peaks are just below clipping, the M•800 requires the following average currents (@120VAC, 60 Hz):

Amplifier Loading	Average Current Required	Peak Current Required
2 ohms per side or 4 ohms bridged	7 A	16 A
4 ohms per side or 8 ohms bridged	4.5 A	11 A
8 ohms per side or 16 ohms bridged	3 A	6.5 A

It is recommended that a stiff supply of AC power be used because the amplifier places high current demands on the AC line. The more power that is available on the line, the louder the amplifier will play and the more peak output power will be available for cleaner, punchier bass.

Under typical conditions, reproducing rock music where musical peaks are just below the clipping point, you can safely connect more than one amplifier to a 15A service as shown:

Amplifier Loading	Maximum Number of Amplifiers on a 15A Service
2 ohms per side or 4 ohms bridged	2
4 ohms per side or 8 ohms bridged	3
8 ohms per side or 16 ohms bridged	4

Due to in-rush current, however, you should avoid turning them all on at the same time. Rather, sequence them on, one at a time, to prevent popping the circuit breaker.

The extension cord used to supply power to the "amp rack" should have a third wire safety ground to avoid presenting a safety hazard. We also recommend using a cord that has conductors large enough to avoid severely limiting the amplifier's ability to supply high currents on transients. With this in mind, we recommend using the following for a fully loaded 15A service:

Extension Cord Length	Wire Gauge
25 feet	14 AWG
50 feet	12 AWG
100 feet	10 AWG



AC Power Distribution

The majority of AC outlets encountered in homes and clubs are served by a 240VAC center-tapped service entrance transformer. This provides two phases of AC power on either side of the center tap at 120V each.

In order to minimize ground loops, the safety grounds for all the outlets should be connected to a common (“star”) grounding point, and the distance between the outlets and the common grounding point should be as short as possible.

If lighting is used in a show, it is preferable to power the lights from one leg of the service, and power the audio equipment from the other leg. This will help minimize noise from the lights coupling into the audio (particularly if SCRs are used).

When setting up for a show, oftentimes you are plugging into an AC power distribution system you know nothing about. You may even be faced with 2-wire outlets that are missing the third safety ground pin. It’s a good idea to have a three-wire AC outlet tester in your toolbox so you can check the outlets yourself to make sure they are wired correctly. These testers will tell you if the polarity of the hot and neutral wires is reversed and if the safety ground is disconnected. *Don’t use an outlet if it is wired improperly!* This is to protect yourself as well as your equipment.

If you find that you must plug into a two-wire outlet, you will need to use a two-wire to three-wire adapter (cheater plug). These come with a metal tab that you put underneath the center screw that holds the AC outlet faceplate in place. This center screw should be grounded. You can check it by connecting the adapter to the outlet and then plugging in your AC outlet tester.

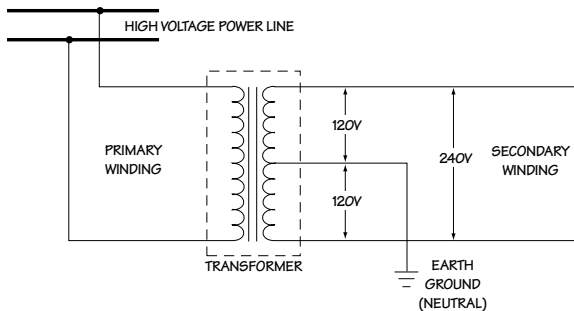

240V Center-Tapped Secondary

INPUT WIRING

Use a high-quality 3-conductor shielded cable to connect the signal between the signal source (mixing console, equalizer, etc.) and the balanced inputs to the amplifier. If you’re using the unbalanced inputs, use a high-quality 2-conductor shielded cable. Your Mackie Dealer can recommend a suitable cable for your application.

OUTPUT WIRING

Use heavy gauge, stranded wire for connecting speakers to the M•800 amplifier’s **SPEAKER OUTPUT** terminals. As the distance between the amplifier and the speakers increases, the thickness of the wire should also increase. Speaker wire has resistance, and when electricity passes through a resistor, power is lost. The thicker the wire, the less resistance it offers, and the more power actually gets to the speakers.

The thickness of wire is rated in gauges. Use the chart below to determine the correct gauge of wire to use according to the distance between the speakers and the amplifier, and the impedance of the load the amplifier is driving. This ensures that the power lost across the speaker wire is less than 0.5 dB.

Wire Length	Load Impedance	Gauge of Wire
Up to 25 ft.	2Ω	14 gauge
	4Ω	16 gauge
	8Ω	18 gauge
Up to 40 ft.	2Ω	12 gauge
	4Ω	14 gauge
	8Ω	18 gauge
Up to 60 ft.	2Ω	10 gauge
	4Ω	12 gauge
	8Ω	16 gauge
Up to 100 ft.	2Ω	8 gauge
	4Ω	10 gauge
	8Ω	14 gauge
Up to 150 ft.	2Ω	6 gauge
	4Ω	8 gauge
	8Ω	12 gauge
Up to 250 ft.	2Ω	4 gauge
	4Ω	6 gauge
	8Ω	10 gauge

APPENDIX A: Service Information

WARRANTY SERVICE

Details concerning Warranty Service are spelled out in the Warranty section on page 27.

If you think your amplifier has a problem, please do everything you can to confirm it before calling for service, including reading through the following Troubleshooting section. Doing so might save you from the deprivation of your Mackie amplifier and the associated suffering.

Of all Mackie products returned for service (which is hardly any at all), roughly 50% are coded “CND” — Could Not Duplicate, which usually means the problem lay somewhere else in the system. These may sound obvious to you, but here are some things you can check:

TROUBLESHOOTING

No power!

- Our favorite question: Is it plugged in? Make sure the AC outlet is live (check with a tester or lamp).
- Our next favorite question: Is the POWER switch on? If not, try turning it on.
- Is the green light next to the power switch illuminated? If not, make sure the AC outlet is live. If so, refer to “No Sound” below.
- The AC line fuse inside the cabinet is blown. *This is not a user-serviceable part.* Refer to “Repair” on the next page to find out how to proceed.

No sound!

- Are the GAIN controls turned all the way down? Slowly turn them up and see if you hear anything.
- Is the signal source turned up? Make sure the signal level from the mixing console (or whatever device immediately precedes the amplifier) is high enough to produce sound in the amplifier.
- Make sure the preamp or mixer does not have a Mute on, or a Tape or Processor loop engaged. If you find something like this, make sure the volume/gain is turned down before disengaging the offending switch.
- If the speakers are wired for BRIDGE mode, make sure the AMP MODE switch is set to BRIDGE .

- Turn the POWER off, check the speaker connections and make sure that there are no strands of wire shorting across the speaker terminals.
- Is the HOT LED lit? Make sure there is cool air available at the front of the amplifier. Make sure there is room at the sides of the amplifier for warm air to exit. Allow the amplifier to cool off.
- Are there fuses in the speaker or in-line fuses in the speaker wire? Check 'em to see if they're blown.
- Make sure the speakers are working properly.

One side is way louder than the other!

- Do the M•800's meters read the same on both sides? If not, your source signal may be delivering an out-of-balance stereo signal.
- Are both GAIN knobs set to the same position?
- Are the speaker(s) impedances matched? (See page 22)
- Try swapping sides: Turn off the amp, swap the speaker cables at the amp, turn the amp back on. If the same side is still louder, the problem is with your speakers or speaker cabling. If the other side is louder now, the problem is with the mixer, the amp, or the line-level cabling.

Poor bass performance

- Check the polarity of the speaker cable connections. You may have your positive and negative connections reversed at one end of one speaker cable. This will make the two speakers out-of-phase and cause a bass reduction.
- Check that the LOW CUT FILTERs are not turned up higher than the range you want to hear.
- Your bass player may need more lessons.

As soon as the music gets loud, the amp shuts down!

- Check the M•800's meters. Be sure that OL is not lighting up frequently or continuously.
- Can the amp breathe? The M•800 amps draw their ventilation air in from the front and out through the side panels. They need plenty of fresh air to stay cool.

Do not block the ventilation ports.

- There may be a dead short somewhere in your speaker setup, or the total impedance of the load is too low. Turn the amp off and rectify that right away.

Something's missing in the mid and high frequencies!

- If you're using horns with compression drivers, please read the CONSTANT DIRECTIVITY section on page 15.

It hurts when I touch my arm, or my leg, or even my head!

- You have a broken finger.

Bad sound!

- Is it loud and distorted? Turn down the signal coming from the mixer or signal source.
- Is the input connector plugged completely into the jack? Check the speaker connections and verify that all connections are tight and that there are no stray strands of wire shorting across the speaker terminals.
- If possible, listen to the signal source with headphones plugged into the console. If it sounds bad there, the problem's not in the amplifier.

Noise/Hum

- Check the signal cable between the mixer and the amplifier. Make sure all connections are good and sound.
- Make sure the signal cables are not routed near AC cables, power transformers, or other EMI-inducing device.
- Is there a light dimmer or other SCR-based device on the same AC circuit as the monitor? Use an AC line filter or plug the amplifier into a different AC circuit.
- If possible, listen to the signal source with headphones plugged into the console. If it sounds noisy there, the problem's not in the amplifier.

REPAIR

Service for the M•800 amplifier is available only from one of our authorized domestic service stations or at the factory, located in sunny Woodinville, Washington. (Service for Mackie amplifiers living outside the United States can be obtained through local dealers or distributors.) If your amplifier needs service, follow these instructions:

1. Review the preceding troubleshooting suggestions. Please.
2. Call Tech Support at 1-800-258-6883, 8am to 5pm PST, to explain the problem and request an RA (Return Authorization) number. Have your amplifier's serial number ready. *You must have an RA number before you can obtain service at the factory or an authorized service center.*
3. Keep this owner's manual. We don't need it to repair the amplifier.
4. Pack the amplifier in its original package, including endcaps and box. This is *very important*. When you call for the RA number, please let Tech Support know if you need new packaging. *Mackie is not responsible for any damage that occurs due to non-factory packaging.*
5. Include a legible note stating your name, shipping address (no P.O. boxes), daytime phone number, RA number, and a detailed description of the problem, including how we can duplicate it.
6. Write the RA number in **BIG PRINT** on top of the box.
7. Ship the amplifier to us. We recommend United Parcel Service (UPS). We suggest insurance for all forms of cartage. Ship to this address:

Mackie Designs

SERVICE DEPARTMENT

16140 Wood-Red Rd. NE Ste 5

Woodinville, WA 98072

8. We'll try to fix the amplifier within three business days. Ask Tech Support for current turn-around times when you call for your RA number. We normally send everything back prepaid using UPS BLUE (Second Day Air). However, if you rush your amplifier to us by Next Day Air, we'll ship it back to you UPS RED (Next Day Air). This paragraph does not necessarily apply to non-warranty service.

APPENDIX B: Technical Information

SPEAKER IMPEDANCES

A speaker's impedance varies with frequency. For example, it may be 4 ohms at 500Hz, and 6 ohms at 120Hz. What you need to know is the average (or nominal) impedance across the speaker's frequency range. This will be printed somewhere on the cabinet, or in the specification section of the missing manual.

If you're just dealing with one speaker per channel, then make sure that the average impedance is greater than or equal to 2 ohms.

In **BRIDGE** mode, make sure that your speaker is greater than or equal to 4 ohms.

If you're driving an assortment of speakers, you have to make sure that the total impedance does not go below these same levels. There are two basic ways of linking multiple speakers: series and parallel. The following sections show how to make the connections and how to work out the total impedance.

SERIES

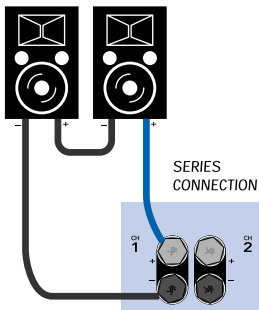

“Series” means that the positive amp output connects to the first speaker's positive terminal, the first speaker's negative terminal connects to the second speaker's positive terminal, the second speaker's negative terminal goes to the amp's negative output. Series connections are not normally used in PA applications because it ruins the amplifier's ability to damp (control) the speakers. The other snag: if one speaker goes out, they all do.

Doing load calculations with series configurations is easy — just add the loads. For instance, two 4-ohm speakers, connected in series, will equal 8 ohms ($4 + 4 = 8$).

PARALLEL

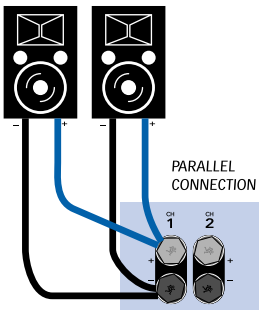

“Parallel” means that the positive amp output connects to the positive terminals of all the speakers, and the negative amp output connects to the negative terminals of all the speakers. If one speaker opens in a parallel configuration, the others will still work, but the load will change. That lets you breathe a little easier (the show will go on), except that you may have a dead speaker and not even know it.

Calculating parallel loads is also easy, as long as each speaker has the same value — just divide the value by the number of speakers.

For example, four 8-ohm speakers, connected in parallel, will equal a 2 ohm load ($8 / 4 = 2$).

If the parallel loads aren't all the same, things get a little more complicated, but nothing that you can't do with a simple calculator. The total impedance (Z_T) is given by the following formula, where Z_1 , Z_2 and Z_3 are the impedances of your speakers.

$$Z_T = \frac{1}{\frac{1}{Z_1} + \frac{1}{Z_2} + \frac{1}{Z_3} + \dots}$$

There are other, more complicated configurations, like series-parallel (using a combination of series and parallel links to arrive at a desired load) and parallel configurations of unmatched loads (usually not recommended). But rather than get too deep into this, let's just summarize the basics, as they apply to you and your M•800:

- The lower the speaker impedance, the more power can be put out by the amplifier.
- Driving lower impedance speakers makes the amplifier work harder and heat up quicker.
- Do not connect a total impedance of under 2 ohms per channel in **STEREO** and **MONO** modes.
- Do not connect a total impedance of under 4 ohms in **BRIDGE** mode.
- Connecting speakers in series or parallel can drastically alter their frequency response.
- Consider using multiple amplifiers rather than overloading one.
- Reduce the low-frequency output by setting the **LOW CUT FILTER** to match the speaker's specifications.
- Never plug the amplifier outputs into anything except speakers (unless you have an outboard box designed to accept speaker level levels).
- Be careful in **BRIDGE** mode as both speaker wires are live. In this mode, do not connect the speaker wires to any external device which is grounded.

M•800 SPECIFICATIONS

Maximum Power:

175 watts per channel into 8 ohms
275 watts per channel into 4 ohms
400 watts per channel into 2 ohms
550 watts into 8 ohms bridged
800 watts into 4 ohms bridged

Note: Power ratings are specified at 120VAC line voltages.

The M•800 power amplifier draws large amounts of current from the AC line with continuous sine wave testing. Accurate measurement of power requires a steady and stable AC supply. This means the line impedance must be very low to insure that the peak AC line voltage does not sag to less than 97% of its value.

If driving highly reactive loads, we recommend that the limiter circuit be engaged.

Continuous Sine Wave Average Output Power, both channels driven:

150 watts per channel into 8 ohms from 40Hz to 20kHz, with no more than 0.025 % THD

225 watts per channel into 4 ohms from 40Hz to 20kHz, with no more than 0.05 % THD

280 watts per channel into 2 ohms from 40Hz to 20kHz, with no more than 0.1 % THD

Bridged mono operation:

450 watts into 8 ohms from 40Hz to 20kHz, with no more than 0.05 % THD

560 watts into 4 ohms from 40Hz to 20kHz, with no more than 0.1 THD

Power Bandwidth:

20Hz to 70kHz (+0, -3 dB)

Frequency Response:

20Hz to 40kHz (+0, -1 dB)

10Hz to 70kHz (+0, -3 dB)

Distortion:

THD, SMPTE IMD, TIM (at rated power)

< 0.025% @ 8Ω

< 0.05% @ 4Ω

< 0.1% @ 2Ω

Signal-to-Noise Ratio:

> 104 dB below rated power into 4 ohms

Channel Separation:

> 70 dB @ 1kHz

Damping Factor:

> 250 from 10 to 400Hz

Input Impedance:

20kΩ balanced

Input Sensitivity:

1.23 volts (+4 dBu) for rated power into 4 ohms

Voltage Gain:

28.0 dB

Maximum Input Level:

9.75 volts (+22 dBu)

Rise Time:

< 5μs

Slew Rate:

Voltage Slew Rate > 40V/μs

> 80V/μs bridged

Current Slew Rate > 20A/μs at 2Ω

CMRR:

> 40 dB, 20Hz to 20kHz

Load Angle:

8(±jx) time independent at 8Ω

4(±jx) time dependent, T > 6 min. at 4Ω

2(1±jx) time dependent, T > 2 min. at 2Ω

Transient Recovery:

< 1μs for 20 dB overdrive @ 1kHz

High Frequency Overload and Latching:

No latch up at any frequency or level.

High Frequency Stability:

Unconditionally stable driving any reactive or capacitive load.

Turn On Delay:

3-4 seconds

Variable Low-Cut Filter:

10Hz (Off) to 170Hz, 2nd Order Bessel

Constant Directivity High Frequency Boost:

2kHz to 5.5kHz (+3 dB points)

6 dB/octave high-frequency shelving filter, (shelving occurs at approximately 30kHz)

Limiters Section:

Complementary Positive and Negative Peak Detecting

Indicators:

5 meter LEDs per channel
-20dB, -9dB, -6dB, -3dB, OL (Overload)

TEMP STATUS
NORMAL/HOT LEDs

Power Consumption:

- 55 watts at idle
- 400 watts with musical program fully loaded
(4 ohms per side, or 8 ohms bridged)
- 600 watts with musical program fully loaded
(2 ohms per side, or 4 ohms bridged)
- 550 watts at rated power into 8 ohms
(continuous sine wave)
- 950 watts at rated power into 4 ohms
(continuous sine wave)
- 1500 watts at rated power into 2 ohms
(continuous sine wave)

AC Drop-out Voltage:

At approximately 65% of rated line voltage

Physical:

Height	3.5 inches (89mm)
Width	19.0 inches (483mm)
Depth	15.25 inches (387mm)
Overall Depth	16.25 inches (413mm)
Weight	28 pounds (12.7kg)

Disclaimer:

Since we are always striving to make our products better by incorporating new and improved materials, components, and manufacturing methods, we reserve the right to change these specifications at any time without notice.

"Mackie," "The Running Man," and "FR Series" are trademarks or registered trademarks of Mackie Designs Inc.

All other brand names mentioned are trademarks or registered trademarks of their respective holders, and are hereby acknowledged.

©2000 Mackie Designs Inc.
All Rights Reserved.
Printed in the U.S.A.

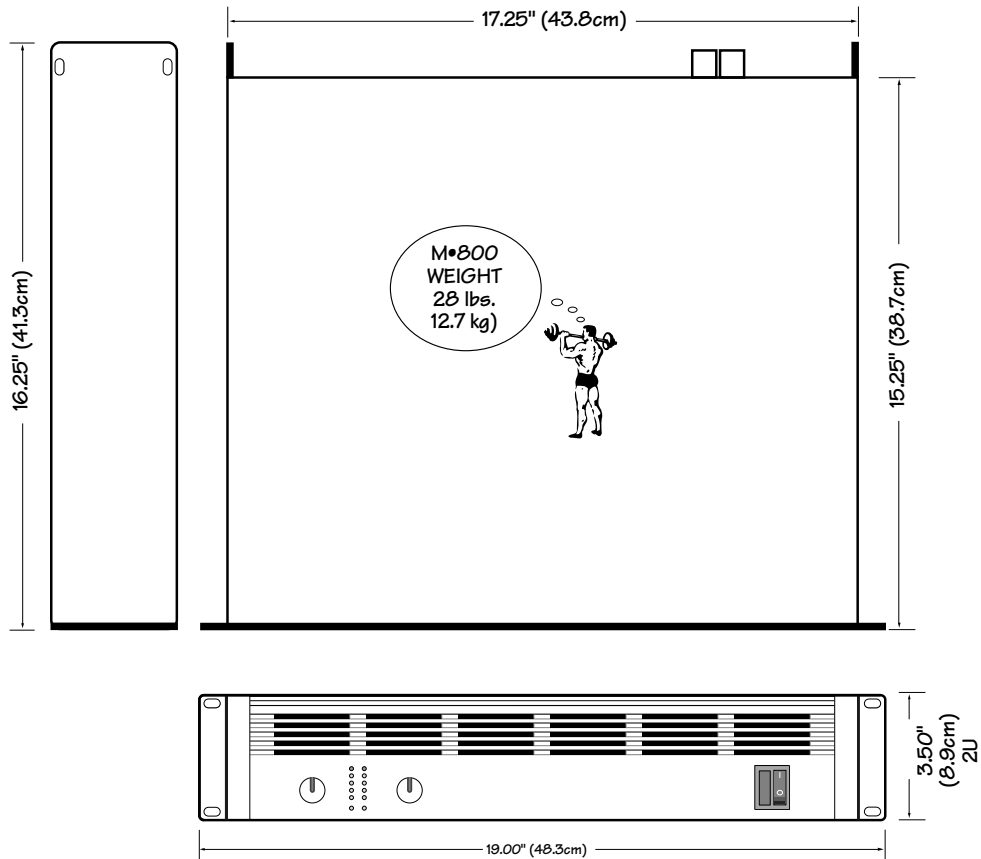

M-800 BLOCK DIAGRAM

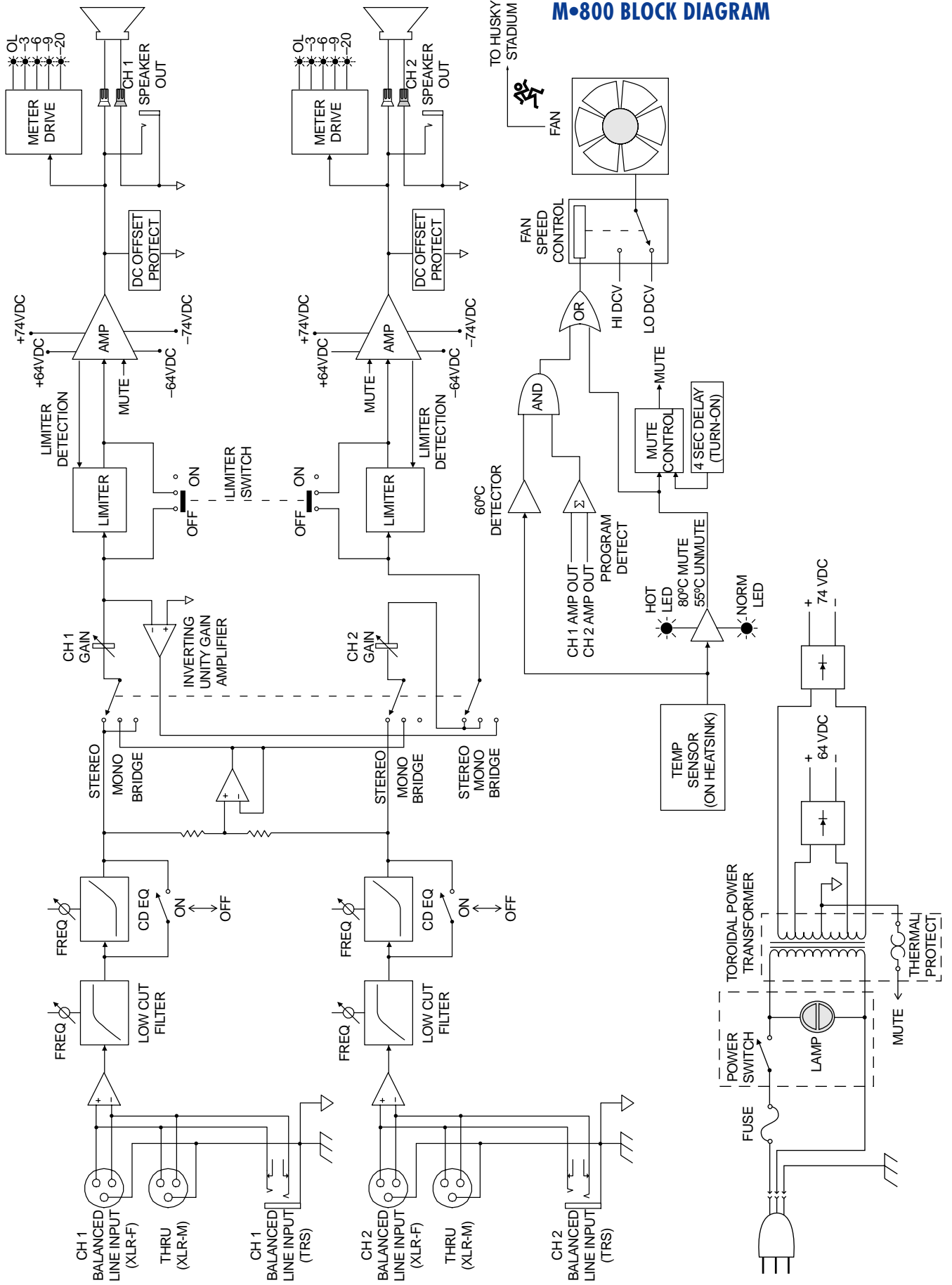

APPENDIX C: Bi-amping and Tri-amping

Most speaker systems in use today are of the two-way or three-way variety. Cone speakers are good at reproducing low and mid-range frequencies, but not high frequencies. Likewise, compression drivers are good at reproducing high frequencies, but definitely not low frequencies. This is why two-way, three-way, and even four-way speaker systems were developed — to improve the efficiency of each individual driver by requiring it to reproduce only the frequencies that it reproduces best.

One method of accomplishing this is through the use of a passive crossover network between the amplifier and the speaker(s). Often the passive crossover is built into the cabinet along with the various drivers. The crossover divides the high-level speaker signal into frequency bands, which are then directed to the appropriate driver. There are some drawbacks to this method, however. The passive crossover adds reactance to the load that

the amplifier sees, which can affect the damping. Power is wasted as heat across the resistors in the crossover, reducing the amount of amplifier power available to the drivers themselves.

Bi-amplified and tri-amplified systems use separate power amplifiers to power each individual low-frequency and high-frequency driver. An electronic crossover (a.k.a. active crossover) is located between the signal source and the power amplifier. The advantages of this method include 1) increased headroom available from each amplifier, since they're amplifying only a portion of the entire audio spectrum; 2) improved damping factor because the amplifier output is connected directly to the driver; 3) improved efficiency because there are no passive resistors to dissipate heat; and 4) flexibility to choose the optimum crossover frequency and crossover slope for the individual drivers in the system.

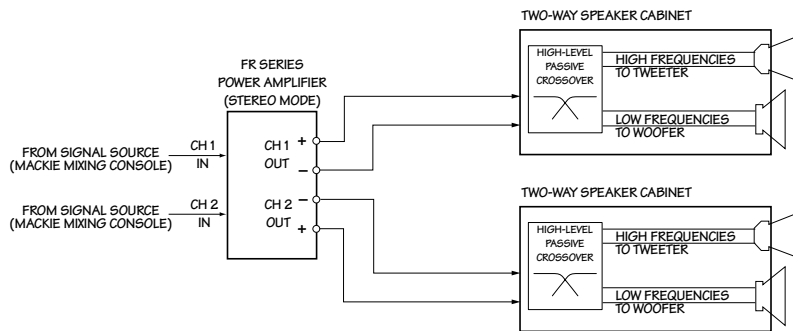

Passive Crossover System

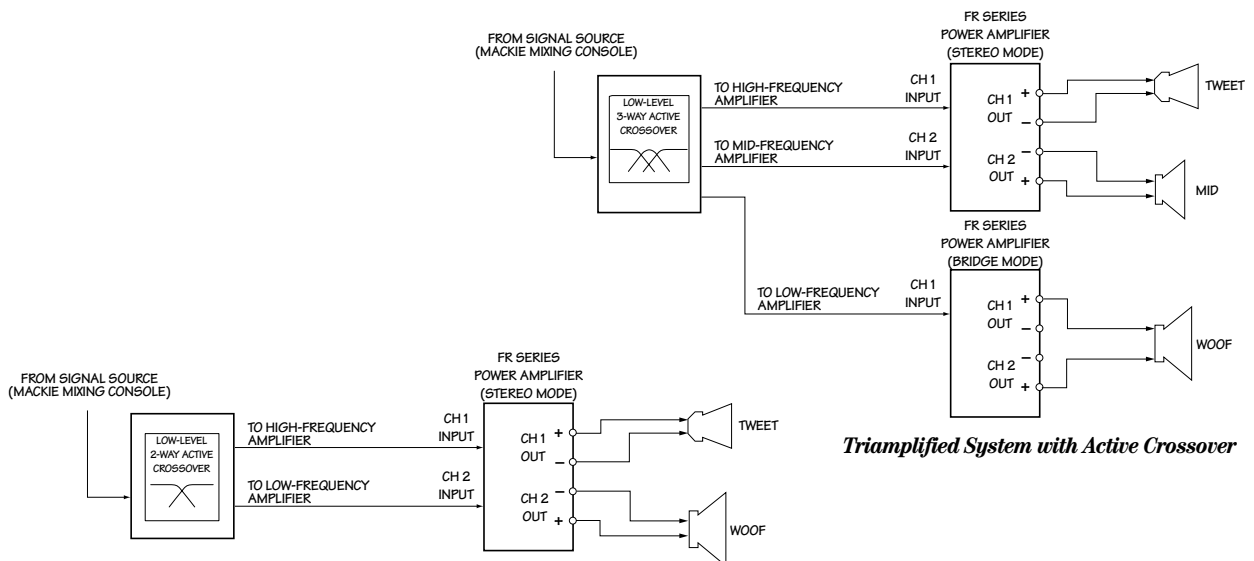

Tri-amplified System with Active Crossover

Bi-amplified System with Active Crossover



M-800 LIMITED WARRANTY

Please keep your sales receipt in a safe place.

A. Mackie warrants all materials, workmanship and proper operation of this FR Series product for a period of **three years** from the original date of purchase. If you complete the optional questionnaire portion of the Product Registration Card, the warranty will be extended for an **additional two years**. If any defects are found in the materials or workmanship or if the product fails to function properly during the applicable warranty period, Mackie, at its option, will repair or replace the product. **This warranty applies only to equipment sold and delivered within the U.S. by Mackie or its authorized dealers.**

B. Failure to return the card will not void the 3-year warranty.

C. Service and repairs of Mackie products are to be performed **only** at the factory (see D below) OR at an Authorized Mackie Service Center (see E below). Unauthorized service, repairs, or modification will void this warranty.

D. To obtain factory service:

1. Call Mackie at 800/258-6883, 8AM to 5PM Monday through Friday (Pacific Time) to get a Return Authorization (RA). Products returned without an RA number will be refused.
2. Pack the FR Series product in its original shipping carton. If you do not have the carton, just ask for one when you get your RA number, and we'll send a shipping carton out promptly. More information on packing can be found in the *Service* section of the appropriate manual. Also include a note explaining exactly how to duplicate the problem, a copy of the sales receipt with price and date showing, and your return street address (no P.O. boxes or route numbers, please!). If we cannot duplicate the problem at the Mackie Factory or establish the starting date of your Limited Warranty, we may, at our option, charge for service time.
3. Ship the product in its original shipping carton, *freight prepaid* to:

**Mackie Designs Inc.
SERVICE DEPARTMENT
16140 Wood-Red Road NE Ste 5
Woodinville, WA, 98072, USA**

IMPORTANT: Make sure that the RA number is plainly written on the shipping carton.

E. To obtain service from an Authorized Mackie Service Center:

1. Call Mackie at 800/258-6883, 8AM to 5PM Monday through Friday (Pacific Time) to get 1) The name and address of your nearest Mackie Authorized Service Center and 2) A return authorization (RA). You must have an RA number before taking your unit to a service center.
2. Make sure that you have a copy of your FR Series sales receipt from the store where you bought the product. It is necessary to establish purchase date and thus determine whether or not your FR Series product is still under warranty. If you can't find it, the Authorized Service Center may charge you for repairs even if your FR Series product is still covered by Mackie's 3-Year Limited Warranty.
3. Make sure that the problem can be duplicated. If you bring your FR Series product to an

Authorized Service Center and they can't find anything wrong with it, you may be charged a service fee.

4. If the Mackie Authorized Service Center is located in another city, pack the FR Series product in its original shipping carton. More information on packing can be found in the *Service* section of the appropriate manual.

5. Contact the Mackie Authorized Service Center to arrange service or bring the FR Series product to them.

F. Mackie and Mackie Authorized Service Centers reserve the right to inspect any products that may be the subject of any warranty claims before repair or replacement is carried out. Mackie and Mackie Authorized Service Centers may, at their option, require proof of the original date of purchase in the form of a dated copy of the original dealer's invoice or sales receipt. Final determination of warranty coverage lies solely with Mackie Designs Inc. or its Authorized Service Centers.

G. Mackie FR Series products returned to Mackie and deemed eligible for repair or replacement under the terms of this warranty will be repaired or replaced within thirty days of receipt by Mackie at our rainforest factory complex. Products returned to Mackie that do not meet the terms of this Warranty will be repaired and returned C.O.D. with billing for labor, materials, return freight, and insurance. Products repaired under warranty at Mackie's factory will be returned freight prepaid by Mackie to any location within the boundaries of the USA.

H. Mackie assumes no responsibility for the quality or timeliness of repairs performed by Mackie Authorized Service Centers.

I. This warranty is extended to the original purchaser and to anyone who may subsequently purchase this product within the applicable warranty period.

J. This is your sole warranty. Mackie does not authorize any third party, including any dealer or sales representative, to assume any liability on behalf of Mackie Designs or to make any warranty for Mackie Designs.

K. THE WARRANTY GIVEN ON THIS PAGE IS THE SOLE WARRANTY GIVEN BY MACKIE AND IS IN LIEU OF ALL OTHER WARRANTIES, EXPRESS AND IMPLIED, INCLUDING THE WARRANTIES OF MERCHANTABILITY AND FITNESS FOR A PARTICULAR PURPOSE. THE WARRANTY GIVEN ON THIS PAGE SHALL BE STRICTLY LIMITED IN DURATION TO THREE YEARS FROM THE DATE OF ORIGINAL PURCHASE FROM AN AUTHORIZED MACKIE DEALER. UPON EXPIRATION OF THE APPLICABLE WARRANTY PERIOD, MACKIE SHALL HAVE NO FURTHER WARRANTY OBLIGATION OF ANY KIND. MACKIE SHALL NOT BE LIABLE FOR ANY INCIDENTAL, SPECIAL, OR CONSEQUENTIAL DAMAGES THAT MAY RESULT FROM ANY DEFECT IN THE MACKIE PRODUCT OR ANY WARRANTY CLAIM. Some states do not allow exclusion or limitation of incidental, special, or consequential damages or a limitation on how long warranties last, so some of the above limitations and exclusions may not apply to you. This warranty provides specific legal rights and you may have other rights which vary from state to state.