

1202/1402-VLZ PRO and Onyx 1220/1620 8-Track Recording

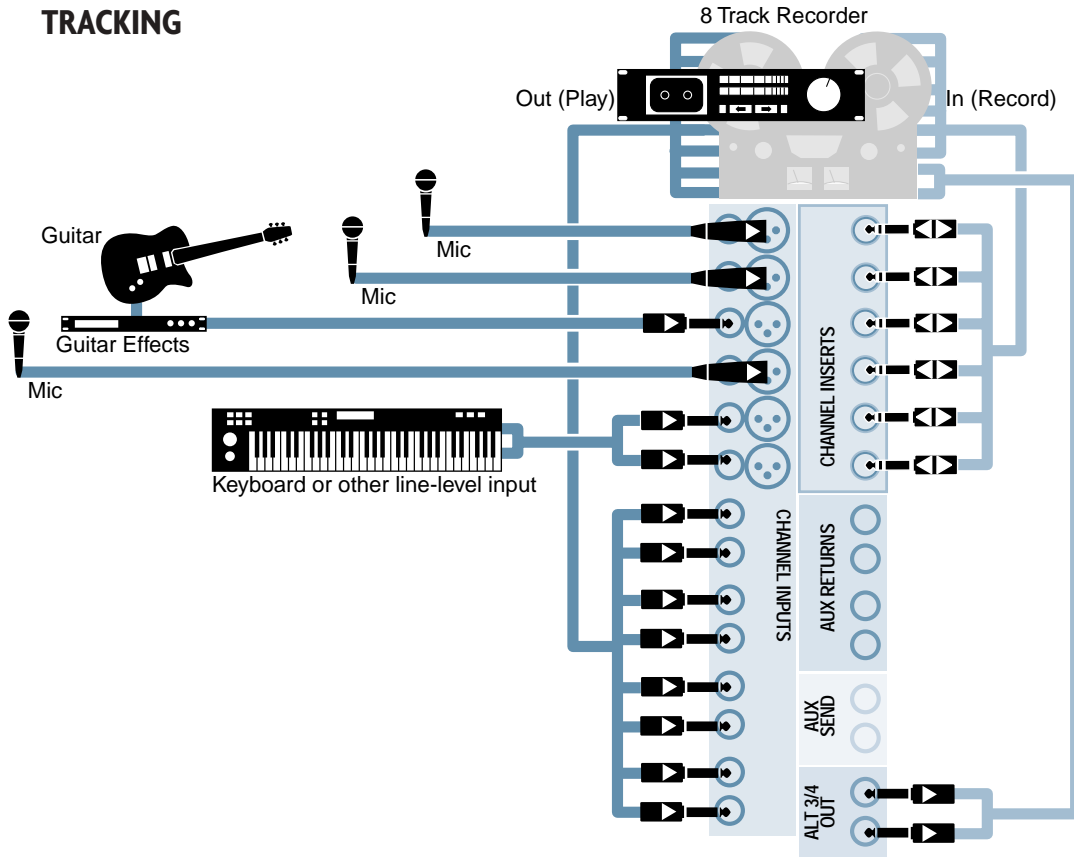

So you bought a brand new 8-track recorder. (OK, we first wrote this in 1990.) Let's say you got a new 8 channel audio interface for your computer. Much as you love peanut butter sandwiches for your three daily meals, maybe it'll still be a few weeks before you can swing the purchase of that new larger mixer. Don't despair. You can do 8-track recording with your 1202 or 1402-VLZ PRO!

Connections for Tracking

Versatile as these small mixers are, pressing them into 8-Track service without moving some cables between tracking and mixing is a bit of a stretch. The same concepts used in the 4-Track setup are used here – split monitoring and use of the ALT and/or direct outputs.

The previous page shows how to hook things up for tracking. We will re-patch a few things for mixdown.

Monitoring Connections

To reduce the amount of cable swapping while tracking, we've connected the recorder outputs to the four pairs of stereo line inputs and assigned them to the MAIN L-R bus (MUTE/ALT switches up). This will allow you to hear all 8 tracks while tracking, but with a bit of a compromise. The illustration on the previous page shows a 1402-VLZ PRO with the recorder outputs connected to Line Inputs 7-14. On the 1202-VLZ PRO and Onyx 1220, you'll have to use Line Inputs 5-12 and juggle the recording inputs to fit. On the larger Onyx 1620, use Line Inputs 9-16.

Since the stereo line inputs are hard panned left and right, anything recorded on odd-numbered tracks will appear in the left speaker (only); even-numbered tracks will appear in the right speaker (only). We'll fix that when mixing, but for tracking, it's the best we can do if we want to keep the maximum number of sources connected to channel inputs.



You'll need to use some of the stereo inputs for monitoring, but if you have only one or two sources for recording, or you're recording only a single part at a pass and you don't mind sharing an input or two among mics, guitars, keyboards, etc., you can move some of the recorder returns to line inputs of the mono channels, giving you full panning capability on some of the tracks while overdubbing.

Recorder Inputs

The tracking diagram shows two tracks fed from the ALT OUTPUTs and the remainder of the tracks fed from INSERT outputs (insert the plug halfway, to the first click). You could also use the Onyx Direct Recording outputs if you have the appropriate cable. You can tailor this to suit your own setup. See the 4-Track Hookup for some of the details and tradeoffs.

Having the ALT outputs connected to the recorder inputs will prove handy when bouncing tracks or if you've set up six mics on the drum kit and want to record two tracks of drums. Using Y-Cables to split the ALT outputs to all odd and even numbered tracks (you'll need to Y the Y's) allows you to quickly route any input to any track when you're in the overdub phase, recording just one or two tracks at a time.

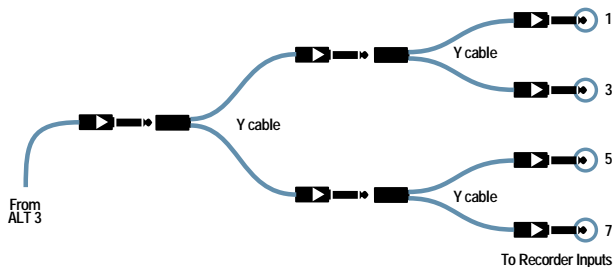

Connecting an INSERT OUT (or Onyx Direct Recording Out) directly to the recorder input gives the cleanest signal path from the mic to the recorder. Feel free to unplug and move cables – that's why they put connectors on them. If you're recording several vocal tracks using the mic connected to Channel 1, move the plug from track to track at the recorder end. Better than that, install a patchbay between the mixer and recorder and just move a cable on the patchbay.

If you choose to use both Insert or Direct outputs and the ALT outputs to feed the recorder, remember what you're monitoring, and what you're not. Insert Sends and Onyx Direct Recording outputs come before the channel fader, so to take those channels out of the monitor mix (remember, you'll be hearing them as they come back from the recorder through the channels you're using for recorder returns), just turn the fader down all the way. That way you won't be hearing the channel twice when you're tracking.



Pushing the plug fully into the INSERT jack when using the Insert as a direct output will take the channel out of the mixer's signal path, but that also wipes out the Solo function and therefore the Level Setting Procedure. Also, if you're feeding recorder tracks from a mixture of Direct outputs and the ALT bus, think twice before

you push the MUTE button when setting up to record a track. That assigns the channel to the ALT busses – no problem if you’re not recording those outputs (or if you intend to record that channel to the ALT-connected recorder tracks), but a big problem if you’re recording on the ALT bus channels in the same pass as you’re recording a direct-fed channel. You’ll record the same signal on two tracks, which will give you headaches when mixing.



Line-level sources such as keyboards can be connected directly to the recorder inputs for tracking as long as the source can provide the proper record level. Certain sources may require additional gain from the mixer. Don’t forget the Level-Setting Procedure when using the mixer as a preamp.

Connections Not Shown

Effects such as reverb can be connected to AUX SEND and RETURN jacks as shown in other applications.

Processors such as compressors or equalizers can be connected in-line with the recorder inputs as shown in the 1202-VLZ PRO 4-Track Recording setup, or connected to the INSERT jacks with an Insert cable if the INSERT outputs aren’t being used as direct outputs.

Control room speakers and headphones are connected to their respective outputs as shown in other setups.

Making Tracks

Refer to the 4-Track Recording setup using the ALT OUTPUTs for details. Monitor the stereo channels while tracking by assigning those channels to the MAIN L-R bus (MUTE/ALT switch up). With the recorder set to the Auto Input Monitor mode, you’ll hear the input to any recorder track that’s record-enabled, and the playback from any recorded track.



Remember that the recorder is part of the monitoring path. In order to hear the input signal in the phones or control room monitors that you’re sending to a track, you must enable Record on that track.

Input Assignments

When recording to a track that’s connected to the ALT outputs, assign the input channel to those outputs by pressing the MUTE/ALT switch down. When recording a track fed from a direct output, you

can also use the MUTE switch to take it out of the monitor path unless you’re also recording to the tape tracks assigned to the ALT inputs in that same pass.



Feedback Alert! Don’t forget to switch off the control room speakers, and monitor on headphones when recording with live mics in the same room.

Bouncing Tracks

With eight tracks available, you’ll have less need to bounce tracks than with a 4-Track recorder, but you’ll need more tracks sooner than you think. See the 4-Track setup for a description of track bouncing.

Panning When Bouncing

There’s one big difference between the 4- and 8-Track setups. With only four recorder tracks to return to the mixer, we were able to employ the stereo mixer channels in their mono mode and could freely pan and assign our recorded tracks when making a bounce. Since all the recorder outputs in this 8-Track setup are returning to stereo channels as stereo pairs, you can’t mix odd and even-numbered tracks together and send them to one of the ALT outputs. Nor can you pan six tracks throughout the left-right field and record that as a bounced stereo pair. The PAN pots on stereo channels don’t allow this. The 1402 and Onyx 1620 have a few more inputs than the 1202 so it’ll take you longer to find yourself backed into this corner, but it’s bound to happen sometime.

The solution is to temporarily unplug some of the sources connected to the mono channels and connect the recorder returns in their place. Tracks recorded as pairs that will remain panned fully left and right in the mix (such as a drum kit) can remain connected to the stereo inputs, but those that you want to pan somewhere in the middle must be re-patched to mono channel inputs.

Remember that a stereo channel with a plug in the LEFT input only becomes a mono channel with full Left-Right panning. If you’ve filled Tracks 1-7 and intend to bounce those to Track 8, you need only pull the Right inputs to the first three stereo channels and plug them into mono channels. You’ll also need to pull the Left input to the 4th stereo channel (that’s the one coming from Track 7) and move that over to a mono mixer channel. Here’s why:

You need to be able to hear the mix of tracks you’re bouncing, so Track 8 must be assigned to the MAIN L-R bus. But since you want Track 7 in the bounce

mix, you can't assign it to ALT 4 bus if its "input mate" is assigned to L-R.

While you're in the neighborhood, move the Track 8 output cable over to the now vacant Left input of its stereo channel so you can pan it to the center.

Once you've re-patched, assign the four mono channels and the first three stereo channels to ALT-3/4 by pressing the MUTE/ALT buttons. Turn the PAN controls fully right. The 4th stereo channel (which now is receiving only the Track 8 signal) remains assigned to MAIN L-R.

Housekeeping

To return to tracking after the bounce pass is completed, put cables back as they were. Remember to return the stereo channels to their MAIN L-R bus assignment.

Since you'll be moving cables a few times during this procedure, it really helps to label them. Neatly printed labels secured to the 1/4" phone plugs with clear tape will save you from an unplanned tour of the spaghetti factory.

Bounce Variations

In the next pass, we'll bounce Tracks 1-6 (and maybe even Track 8) to Track 7, so we'll do some similar cable juggling, only in this case leaving the Track 7 cable plugged into the stereo channel input alone. Assigning tape return channels to ALT-3/4 and panning full left will send the bounce mix where you want it.

If you have tracks that you want to bounce to a stereo pair, assign them to the ALT busses, monitor the pair of recorder tracks to which you're bouncing (assigning them to the MAIN busses), and adjust the PAN controls of the tracks being bounced so that you hear the stereo positioning that you want to appear in the final mix. A typical application would be that you've recorded your drums on several individual tracks and now want to use those tracks for other purposes, but want to keep the drum recording in stereo.

Live Multitrack In The Studio

Say your band's got its act together and you're not interested in a lot of fancy overdubbing and track bouncing; you just want to capture eight sources direct to eight tracks and mix afterward. Here's a really neat trick:

Remember that a channel INSERT is both an output and an input. By using the channel inserts of the first four (six on the 1402) mixer channels, you have clean mic preamp outputs that can feed recorder tracks directly. The INSERTS also serve as mono inputs for the recorder returns. With the recorder connected with Insert cables just as if it were an in-line effect processor, the TRIM control serves as a record level control, and the rest of the channel controls operate on the recorder return signal.

When tracking, with the recorder in Auto Input Monitor mode, you'll hear the mic input when recording (or in Record Ready). When playing back, the track will go through the channel EQ and fader, as well as be available to the effect sends.

A typical setup might be with four mics going to tracks 1-4 straight from the Insert Sends, and four line level sources (keyboards, guitar processors, or outboard mic preamps) connected directly to the recorder inputs for tracks 5-8. With recorder outputs 1-4 connected to mixer channels 1-4 through the insert returns and tracks 5-8 connected to odd-numbered stereo line inputs, you'll have full pan, EQ, and level control of all eight tracks both for monitoring while recording and for mixdown. Here's a simplified diagram of this setup:

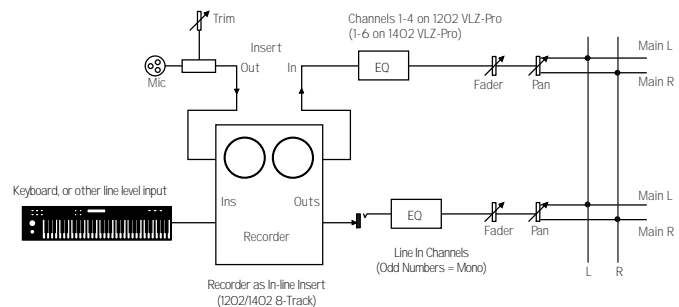

The insert sends and returns are unbalanced, so if your recorder uses balanced inputs and outputs you may need some adapters on the recorder end. You'll have to do some patching if you want to bounce tracks. This same arrangement also works just fine for larger mixers, such as the 1604-VLZ PRO.

Mixdown

Once you've recorded all the parts, re-patch once more so that the recorder returns are connected to mono inputs, either on the mono channels or the Left input of stereo channels. Assign all the recorder returns to the MAIN L-R bus, and mix to taste.

The 2-track mixdown recorder is shown connected to the TAPE OUTPUTS where it will receive the stereo mix. It could also be connected to the MAIN OUTPUTS if they better match the operating level and/or connector type. Listen to your mix by selecting TAPE as the C/R SOURCE.

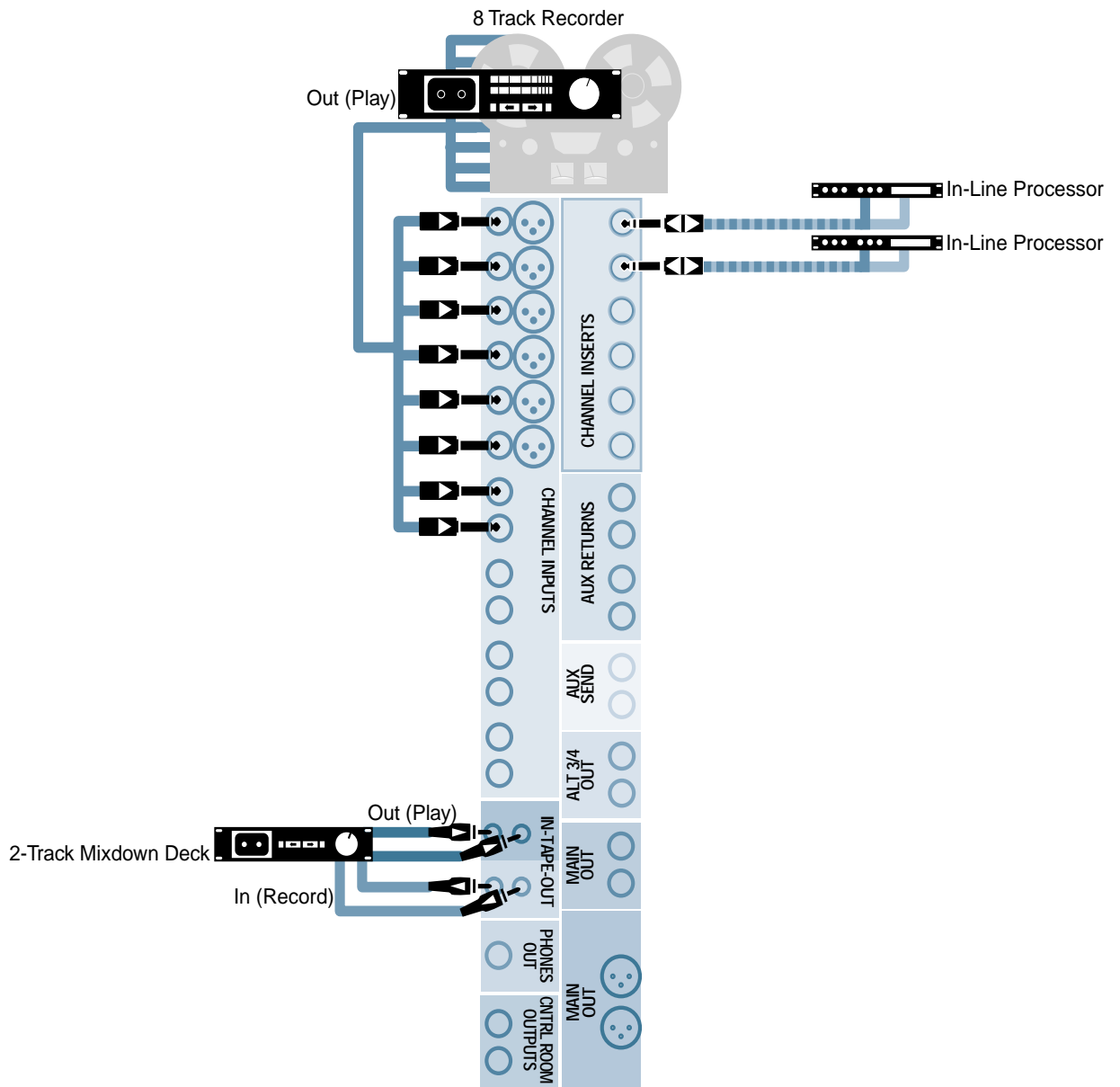

Notes
