

1642-VLZ PRO Stereo PA

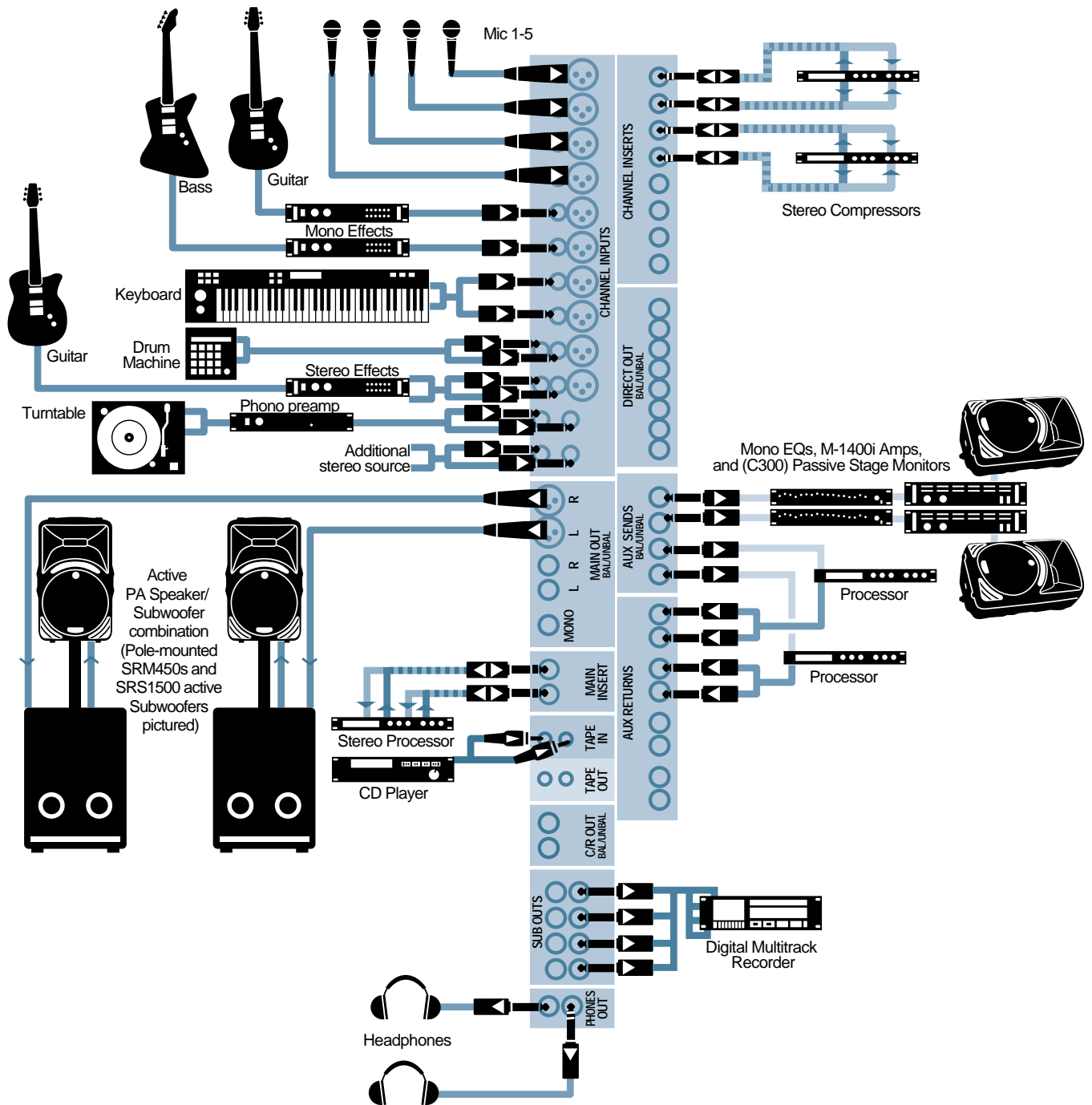

This hookup is a variation on the 1604-VLZ PRO stereo PA application. Refer to the 1604 hookup for details.

This example takes advantage of the 1642's multiple stereo line inputs. Main active speakers with built-in power amplifiers and active subwoofers are shown here, but of course you can use separate speakers and power amplifiers.

AUX 1 and AUX 2 are used for two monitor mixes:

- Two stereo effects processors are fed from AUX 3 and AUX 4, returning to the mix on stereo RETURNS 1 and 2.
- The (EFFECTS TO MONITOR) control TO AUX SEND 1 sends the output of the processor connected to RETURN1, to the monitors fed from AUX SEND 1.
- The control TO AUX SEND 2 sends the output of the other effect processor to the monitors fed from AUX SEND 2.

A 4-track recorder is shown connected to the SUB outputs. If you have an 8-track (or more) recorder, you'll probably want to use both the SUB OUTPUTS and DIRECT OUTPUTS. Divide your sources up so that those connected to the stereo inputs (which don't have INSERTs) are routed to the subgroups. Assign the subgroups to the LEFT and RIGHT busses to put them into the main mix.